



GT50/120/0005

**ROAD TRAFFIC REGULATION ACT 1984 – SECTIONS 64 AND 65  
AUTHORISATION OF TRAFFIC SIGNS AND SPECIAL DIRECTIONS**

The Secretary of State for Transport, in exercise of his powers under Section 64 of the Road Traffic Regulation Act 1984, for the purpose of requiring traffic to stop for a short period during cycle races, hereby:-

1. authorises the placement on roads for which Oxfordshire County Council is the traffic authority, at those locations that a chief officer of police has given authority for the sign to be placed, of a traffic sign (hereinafter referred to as “the authorised sign”) conforming as to size, colour and character with the sign shown on the attached drawing numbered NP-SCR; and
2. directs that the authorised sign may be placed only by personnel trained to do so in accordance with the relevant British Cycling protocol; and
3. directs that the authorised traffic sign may be placed only in connection with a cycle race approved under the Cycle Racing on Highways Regulations 1960; and
4. directs that the authorised sign may not be placed on a road subject to a speed limit greater than 60mph; and
5. directs that the post or other support specifically provided for the purpose shall be of any single colour.
6. (i) The sign, subject to sub-paragraph (iii) shall be illuminated by means of retroreflecting material and, must be internally light throughout the hours of darkness.
  - (ii) (a) the parts of the sign coloured yellow shall be fluorescent;
  - (b) the parts of the sign coloured red may be fluorescent.



GT50/120/0005

(iii) The parts of the sign coloured black shall not be illuminated by means of retroreflecting material.

(iv) In this paragraph the word "part" in relation to the sign means any part of the sign which is uniformly coloured and bounded by parts of a different colour.

The provisions of Regulation 12 of the Traffic Signs Regulations 2002 (S.I. 2002 No. 3113) shall apply to the authorised sign in the same manner as they apply to the sign shown in diagram 7031 in Schedule 12 Part I to those Regulations.

Section 36 of the Road Traffic Act 1988 shall apply to the authorised sign.

Dated 4 August ..... 2011

Signed by authority of the Secretary of State

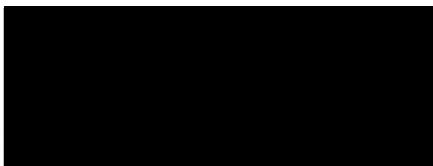

A Delegated Official of the Department for Transport



Drawing No.

NP-SCR

Related Drawing

S 24

Before using this drawing, confirm that it has not been superseded.

© CROWN COPYRIGHT

NOTES: 1. The legend is from the Transport Heavy alphabet at the x-height shown.

2. Symbol details are on drawing No. S 24.

3. The tile outlines do not form part of the sign.

4. COLOURS: -

Background ----- YELLOW

Border ----- RED

Legend, Bar and Symbol ---- BLACK

5. A sign shall comprise a roundel and a pole on which the roundel is mounted.

6. The design shall be shown on one side of the sign only. The reverse side must be entirely coloured in black or grey.

7. Where alternative dimensions are shown in brackets, the dimensions for other elements must correspond with one another so that the shape and proportions of the sign are as shown.

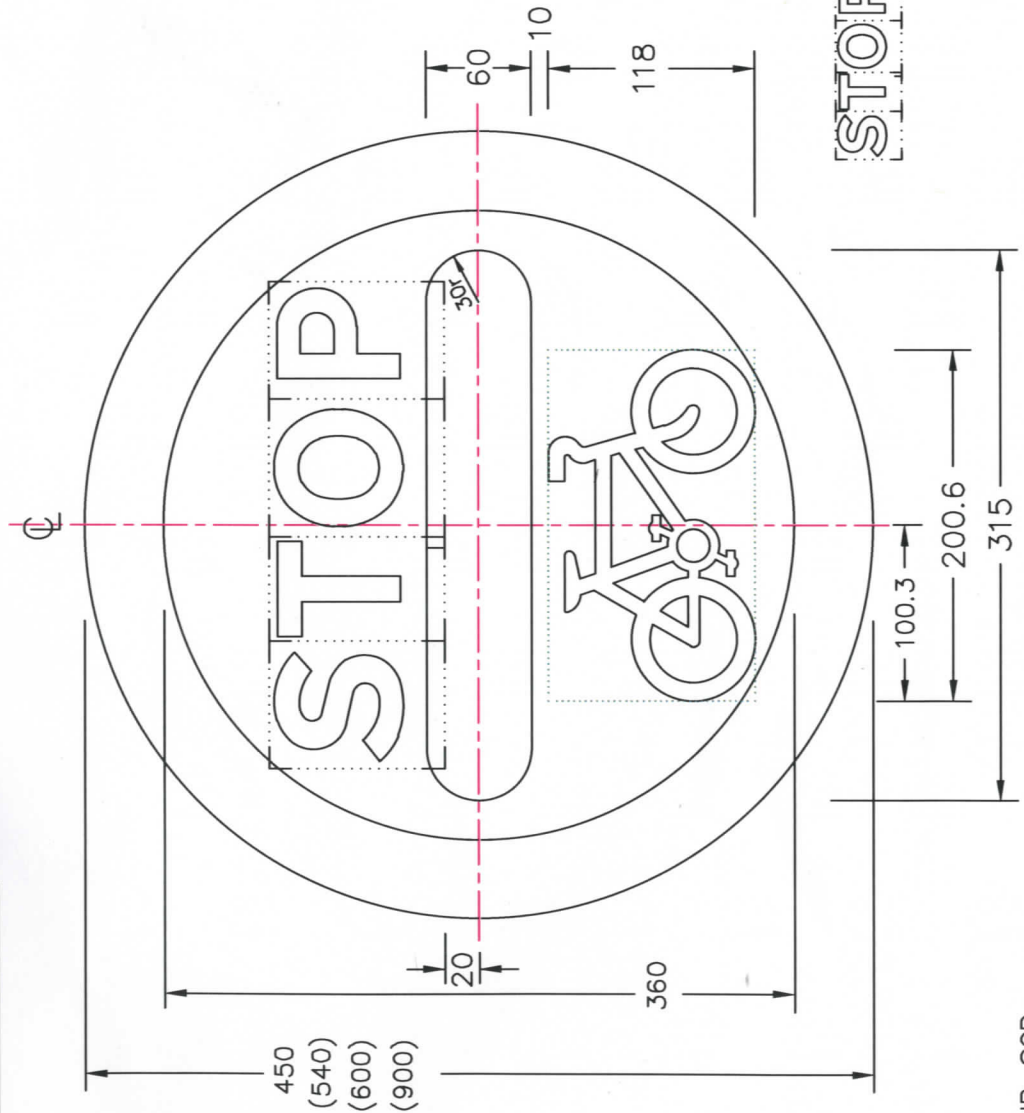

NP-SCR

Title:

Regulatory Sign

STOP CYCLE RACE

Issue: Date:

A: 08.02.11

B:

C:

Drawn by:

A.K.

Approved by:

J.B.

Dimensions:

MILLIMETRES

Drawing No.

NP-SCR

Department for  
**Transport**