



ROAD TRAFFIC REGULATION ACT 1984 – SECTIONS 64 AND 65

The Secretary of State for Transport, in exercise of his powers under Sections 64 and 65 of the Road Traffic Regulation Act 1984 and of all other enabling powers, in accordance with the requirements of Direction 57(3) of the Traffic Signs General Directions 2002 (Part II of SI 2002 No. 3113) and having regard to Direction 59, hereby:-

- 1) approves the road studs specified below for the purposes of carrying out road tests in accordance with the provisions of British Standard BS EN 1463-1:2000 (as required by draft Standard BS EN 1463-3 Pt2) on the northbound carriageway of the A1(M) between Junctions 61 and 62; and
- 2) directs that this approval shall expire on 1 June 2014

SPECIFICATION

Product identification	Sernis Solar Road Studs SR-15, SR-20 and SR-21
Description	Unidirectional or Bidirectional white road stud with LED illumination
Performance	In accordance with draft Standard BS EN 1463-3 Pt1.
To be of a size and type shown in the set of drawings marked with the Department's number	GT50/056/0012-1

Dated: 4 December 2012

Signed by the authority of the Secretary of State

.....

A Delegated Official of the Department for Transport

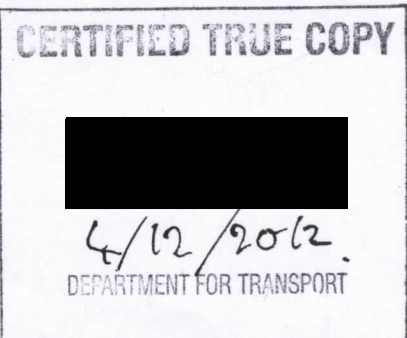

SR-15 - Solar Road Studs

Product introduction

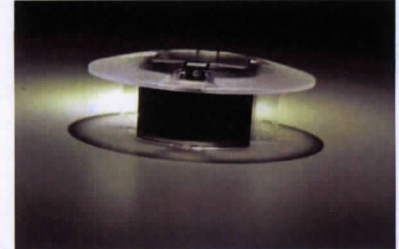
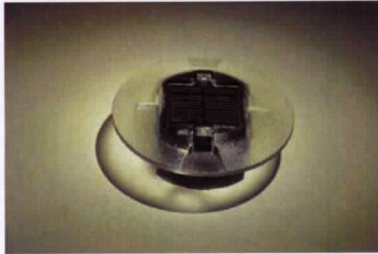

- Solar panel with light level detector and battery energy storage
- Uni-directional or Bi-directional LED's (single or dual)
- No screws
- 100% polycarbonate

Electrical Characteristics	
Power	Battery (NI-MH)
Autonomy in the dark (NI-MH) after full charge	200 hours
Working temperature	-25°C to +85°C
Mechanical Characteristics	
Physical dimensions	Diameter 144mm Rising from road surface: 12 mm (to centre of parable) Installation depth into carriageway: 45mm
Stud body	Base – Polycarbonate Upper cap – Polycarbonate
Mechanical Resistance	60 Tons



arts m

REMA Nikkalite

T: 01928 579 966 F: 01928 579 965 E: uksales@rennicks.com

www.rennicksuk.com

Registered in the United Kingdom No. 2101567 VAT No. GB 464 633633



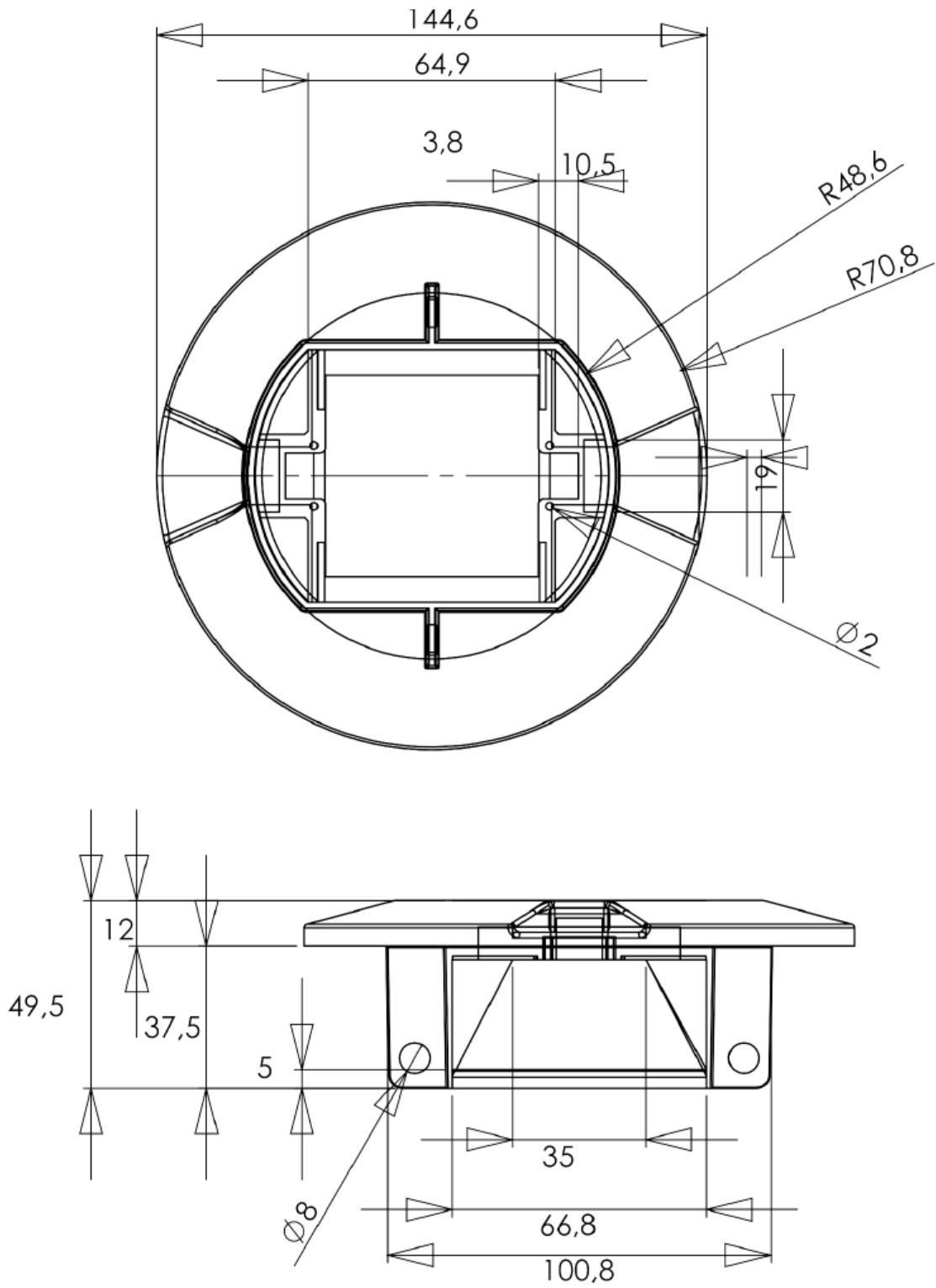

SR 15 dimensional views

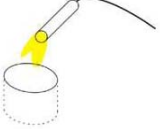

Installation into carriageway

- As required by Chapter 5.
- Sealing compound; refer to Triflex R238 manufacturer's instructions for correct mixing and use.

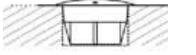
<p>1) Drill hole 45mm deep using a 110mm diameter bit.</p>	
<p>2) Remove all debris from inside hole and around the hole edge. 3) Dry the hole using a blow torch.</p>	
<p>4) Pour Triflex R238 Resin sealing compound into each hole to approximately 50% of depth; 40mm from top of hole. 5) Orientate SR 21 to the direction of traffic and firmly press into the hole. 6) Gently tap top of stud with a rubber mallet to seat the stud correctly. 7) Remove excess Triflex sealing compound. 8) Ensure shoulder of stud rest on carriageway surface. 9) Scoop up excess sealing compound from edges of stud. 10) Ensure no sealing compound is on surface of stud.</p>	 
<p>11) Allow Triflex to dry for approximately 1 hour before traffic over the studs.</p>	

Declaração de Conformidade CE

EC Declaration of Conformity

Serve a presente declaração para certificar que o produto abaixo descrito foi projectado e fabricado em conformidade com a(s) seguinte(s) norma(s) ou documento(s) normativo(s):

This is to certify that the product subsequently referred to was designed and manufactured in conformity with the following standard(s) or other normative document(s):

EMISSÃO/EMISSION

EN 50293:

EN 55022 (2006) + A1 (2007)

IMUNIDADE/IMMUNITY

EN 50293:

EN 61000-4-2 (1995) + A1 (1998) + A2 (2001)

EN 61000-4-3 (2006) + A1 (2008)

EN 61000-4-8 (1993) + A1 (2001)

e cumpre(m) o disposto nas seguintes directivas CE:

and is in accordance with the provisions of the following EC Directives:

CEM 2004/108/CE

Produto/Product Marcador Solar Autónomo/ **Solar Stud**

Marca Comercial / Trademark **SR15-xxx**

Ano de aposição da marcação CE: **2009**

Year in Which the CE marking was affixed:

Local e data: **Braga, 2009-09-16**

Place and Date

Nome fornecedor/Name of supplier: **SERNIS – Soluções Tecnológicas, LDA
Quinta do Carreiro, lote 9 – Frossos
4700 – 154 Braga - Portugal**

Responsável com poder para obrigar a empresa:

Legally binding signature:

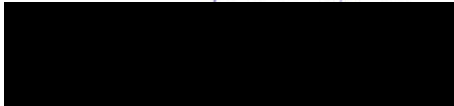
**Eng. Fernando Afonso
(Director Geral/General Director)**

SR-20 - Solar Road Studs



Product introduction

- Solar panel with light level detector and battery energy storage
- Uni-directional or Bi-directional LED's (single or dual)

Electrical Characteristics	
Power	Battery (NI-MH)
Autonomy in the dark (NI-MH) after full charge	200 hours
Working temperature	-25°C to +85°C
Mechanical Characteristics	
Physical dimensions	Diameter 144mm Rising from road surface: 15 mm (to centre of parable) Installation depth into carriageway: 80mm
Stud body	Base – Aluminium Upper cap – Aluminium and Polycarbonate
Mechanical Resistance	20 Tons



REMA Nikkalite

T: 01928 579 966 F: 01928 579 965 E: uksales@rennicks.com

www.rennicksuk.com

Registered in the United Kingdom No. 2101567 VAT No. GB 464 633633





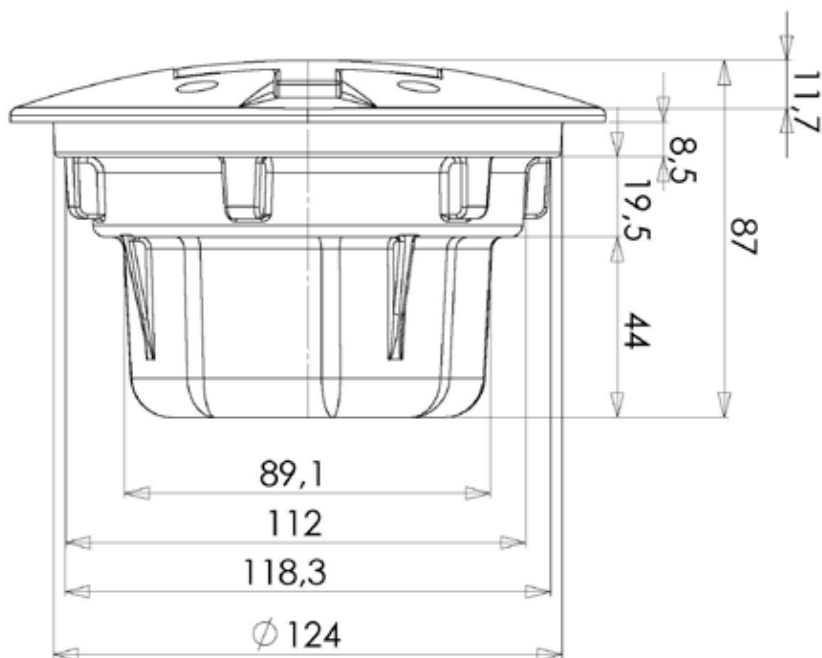
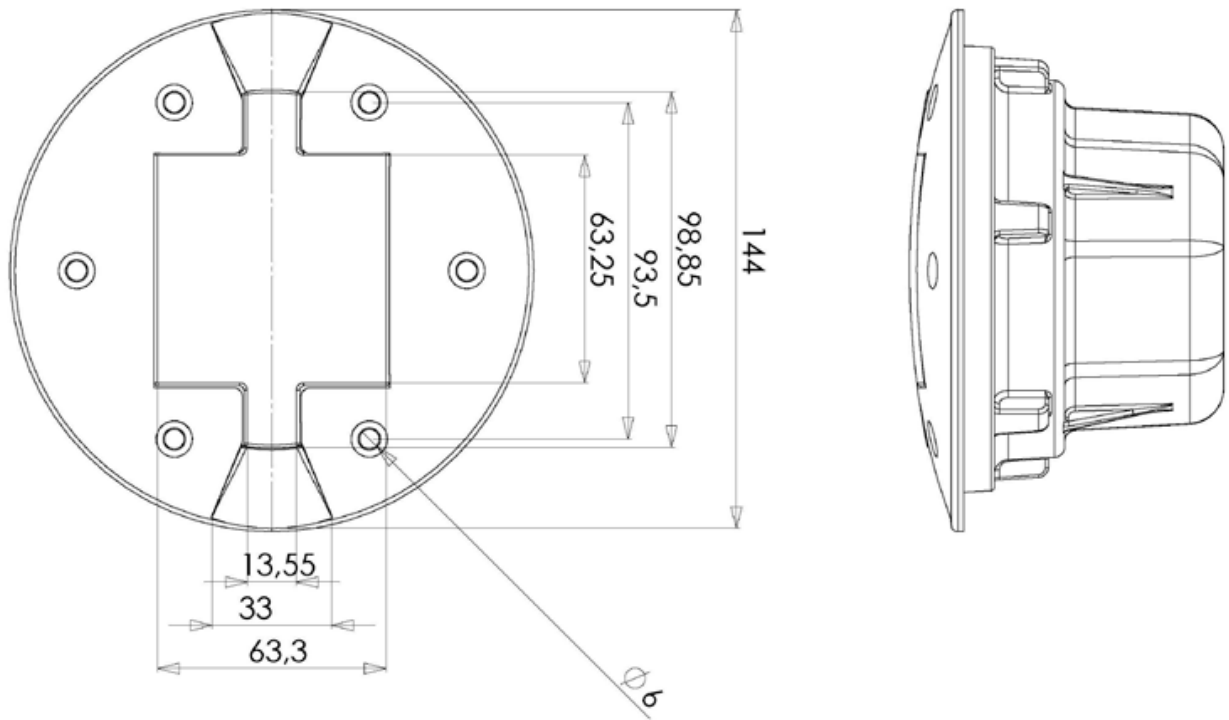

Rennicks U.K.
CLEARLY BETTER

SR 20 dimensional views

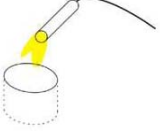

Installation into carriageway

- As required by Chapter 5.
- Sealing compound; refer to Triflex R238 manufacturer's instructions for correct mixing and use.

<p>1) Drill hole 80mm deep using a 130mm diameter bit.</p>	
<p>2) Remove all debris from inside hole and around the hole edge. 3) Dry the hole using a blow torch.</p>	
<p>4) Pour Triflex R238 Resin sealing compound into each hole to approximately 50% of depth; 40mm from top of hole. 5) Orientate SR 20 to the direction of traffic and firmly press into the hole. 6) Gently tap top of stud with a rubber mallet to seat the stud correctly. 7) Remove excess Triflex sealing compound. 8) Ensure shoulder of stud rest on carriageway surface. 9) Scoop up excess sealing compound from edges of stud. 10) Ensure no sealing compound is on surface of stud.</p>	 
<p>11) Allow Triflex to dry for approximately 1 hour before traffic over the studs.</p>	

Declaração de Conformidade CE

EC Declaration of Conformity

Serve a presente declaração para certificar que o produto abaixo descrito foi projectado e fabricado em conformidade com a(s) seguinte(s) norma(s) ou documento(s) normativo(s):

This is to certify that the product subsequently referred to was designed and manufactured in conformity with the following standard(s) or other normative document(s):

EMISSÃO/EMISSION

EN 50293:
EN 55022 (2006) + A1 (2007)

IMUNIDADE/IMMUNITY

EN 50293:
EN 61000-4-2 (1995) + A1 (1998) + A2 (2001)
EN 61000-4-3 (2006) + A1 (2008)
EN 61000-4-8 (1993) + A1 (2001)

e cumpre(m) o disposto nas seguintes directivas CE:

and is in accordance with the provisions of the following EC Directives:

CEM 2004/108/CE

Produto/Product Marcador Solar Autónomo/ Solar Stud

Marca Comercial / Trademark SR20-xxx

Ano de aposição da marcação CE: 2008

Year in Which the CE marking was affixed:

Local e data: Braga, 2008-10-27

Place and Date

Nome fornecedor/Name of supplier: SERNIS – Soluções Tecnológicas, LDA
Quinta do Carreiro, lote 9 – Frossos
4700 – 154 Braga - Portugal

Responsável com poder para obrigar a empresa:

Legally binding signature:

Eng. Fernando Afonso
(Director Geral/General Director)

SR-21 - Solar Road Studs

Product introduction

- Solar panel with light level detector and battery energy storage
- Bi-directional dual LED (2 LED's each direction)
- Reflector

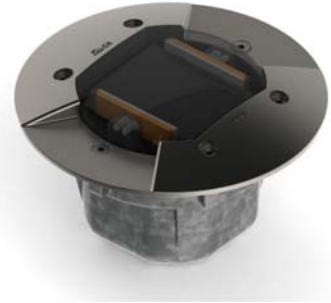

Electrical Characteristics	
Power	Battery (NI-MH)
Autonomy in the dark (NI-MH) after full charge	200 hours
Working temperature	-25°C to +85°C
Mechanical Characteristics	
Physical dimensions	Diameter 155mm Rising from road surface: 17 mm (to centre of parable) Installation depth into carriageway: 80mm
Stud body	Base – Aluminium Upper cap – Aluminium and Polycarbonate
Mechanical Resistance	In excess of 15 Tons



REMA Nikkalite

T: 01928 579 966 F: 01928 579 965 E: uksales@rennicks.com

www.rennicksuk.com

Registered in the United Kingdom No. 2101567 VAT No. GB 464 633633



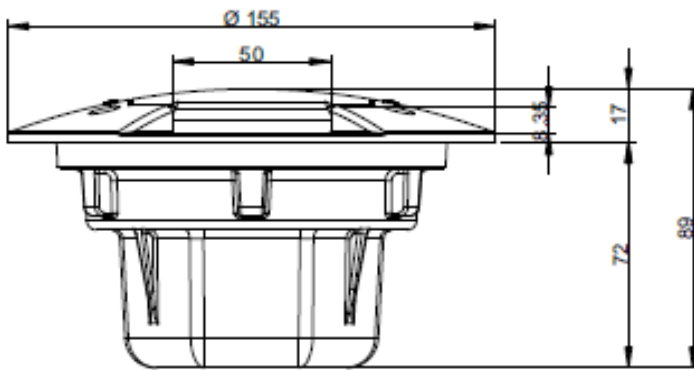
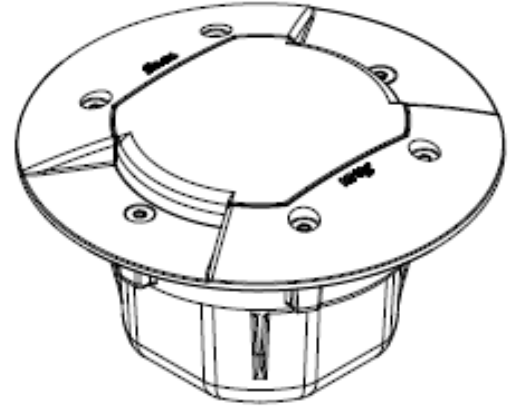
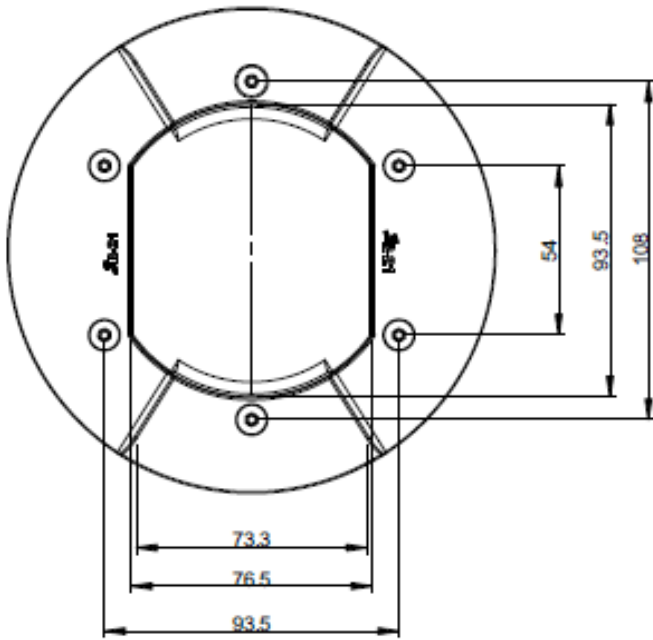

Rennicks U.K.
CLEARLY BETTER

SR 21 dimensional views

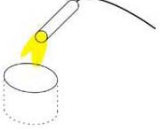

Installation into carriageway

- As required by Chapter 5.
- Sealing compound; refer to Triflex R238 manufacturer's instructions for correct mixing and use.

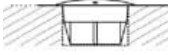
<p>1) Drill hole 80mm deep using a 130mm diameter bit.</p>	
<p>2) Remove all debris from inside hole and around the hole edge. 3) Dry the hole using a blow torch.</p>	
<p>4) Pour Triflex R238 Resin sealing compound into each hole to approximately 50% of depth; 40mm from top of hole. 5) Orientate SR 21 to the direction of traffic and firmly press into the hole. 6) Gently tap top of stud with a rubber mallet to seat the stud correctly. 7) Remove excess Triflex sealing compound. 8) Ensure shoulder of stud rest on carriageway surface. 9) Scoop up excess sealing compound from edges of stud. 10) Ensure no sealing compound is on surface of stud.</p>	 
<p>11) Allow Triflex to dry for approximately 1 hour before traffic over the studs.</p>	

Declaração de Conformidade CE
EC Declaration of Conformity

Declaração do fabricante relativamente à validade do certificado do produto “SR20” no que diz respeito ao produto “SR21” desenvolvido pela SERNIS.

Declaration of the manufacturer concerning the validity of the certificate regarding the “SR20” with respect to the product “SR21” developed by SERNIS.

Serve a presente declaração para certificar que o marcador de chão “SR21” desenvolvido pela empresa SERNIS tem por base a mesma eletrónica incluída no produto “SR20”.

Todas as certificações presentes para o produto “SR20” são deste modo válidas para o produto “SR21”.

This is to certify that the road stud “SR21” developed by the company SERNIS are based on the same electronic included in product “SR20”.

All the certifications for this product “SR20” are therefore also valid for the respective “SR21” road stud.

Produto: / Product:	Marcador chão SR21 Road stud SR21
Marca Comercial: / Trademark:	SR21
Ano de aposição da marcação CE: Year in Which the CE marking was afixed:	2012
Local e data: / Place and Date:	Braga, 2012-02-14
Nome fornecedor: / Name of supplier:	Sernis – Soluções Tecnológicas, Lda Quinta do Carreiro, Lote 9 – Frossos 4700-154 – Braga - Portugal
Responsável empresa: Legally binding signature:	 Eng. Fernando Aronso (Diretor Geral/General Director)

Declaração de Conformidade CE

EC Declaration of Conformity

Serve a presente declaração para certificar que o produto abaixo descrito foi projectado e fabricado em conformidade com a(s) seguinte(s) norma(s) ou documento(s) normativo(s):

This is to certify that the product subsequently referred to was designed and manufactured in conformity with the following standard(s) or other normative document(s):

EMISSÃO/EMISSION

EN 50293:
EN 55022 (2006) + A1 (2007)

IMUNIDADE/IMMUNITY

EN 50293:
EN 61000-4-2 (1995) + A1 (1998) + A2 (2001)
EN 61000-4-3 (2006) + A1 (2008)
EN 61000-4-8 (1993) + A1 (2001)

e cumpre(m) o disposto nas seguintes directivas CE:

and is in accordance with the provisions of the following EC Directives:

CEM 2004/108/CE

Produto/Product Marcador Solar Autónomo/ Solar Stud

Marca Comercial / Trademark SR20-xxx

Ano de aposição da marcação CE: 2008

Year in Which the CE marking was affixed:

Local e data: Braga, 2008-10-27

Place and Date

Nome fornecedor/Name of supplier: SERNIS – Soluções Tecnológicas, LDA
Quinta do Carreiro, lote 9 – Frossos
4700 – 154 Braga - Portugal

Responsável com poder para obrigar a empresa:

Legally binding signature:

Eng. Fernando Afonso
(Director Geral/General Director)