



**ROAD TRAFFIC REGULATION ACT 1984 – SECTIONS 64 AND 65  
AUTHORISATION OF TRAFFIC SIGNS AND SPECIAL DIRECTIONS**

The Secretary of State for Transport, in exercise of his powers under Sections 64 and 65 of the Road Traffic Regulation Act 1984, and of all other powers enabling him in that behalf, for the purpose of informing drivers of the speed limit on roads in the New Forest in Hampshire, hereby:-

1. authorises the erection at appropriate sites on roads within the area shaded within the red dotted boundary line on the attached plan numbered GT50/050/0027-1 of a traffic sign (hereinafter referred to as “the authorised sign A”) conforming as to size, colour and character with the sign referenced “Type A” shown in the attached set of drawings numbered GT50/050/0027-2; and
2. authorises the erection at the said sites of a traffic sign (hereinafter referred to as “the authorised sign B”) conforming as to size, colour and character with the sign referenced “Type B” shown in the said set of drawings; and
3. authorises the erection at the said sites of a traffic sign (hereinafter referred to as “the authorised sign C”) conforming as to size, colour and character with the sign referenced “Type C” shown in the said set of drawings; and
4. authorises the erection at the said sites of a traffic sign (hereinafter referred to as “the authorised sign D”) conforming as to size, colour and character with the sign referenced “Type D” shown in the said set of drawings, save that in the bottom panel the name of a village may be varied; and
5. authorises the erection of a traffic sign (hereinafter referred to as “the authorised sign F”) conforming as to size, colour and character with the sign referenced “Type F” shown in the said set of drawings; and



6. authorises the placing of a traffic sign consisting of a road marking (hereinafter referred to as "the authorised road marking G") conforming as to size, colour and character with that referenced "RM1" in the said set of drawings; and
7. authorises the placing of a traffic sign consisting of a road marking (hereinafter referred to as "the authorised road marking H") conforming as to size, colour and character with that referenced "RM2" in the said set of drawings; and
8. directs that it is a condition of this authorisation that the authorised signs A to D and F and the authorised road markings G and H may be placed only to indicate the effect of a corresponding Traffic Regulation Order; and
9. directs, without prejudice to any statutory provisions to the like effect, that it is a condition of this authorisation that the placing of the authorised signs A to D and F and the authorised road markings G and H at or near the said site shall continue to have effect only until such day as may be appointed by one month's notice given by the Secretary of State in writing to the traffic authority for the removal or alteration of the authorised signs A to D and F and the authorised road markings G and H and on that day the said authorisation shall, without prejudice to the giving of any further authorisation or direction, cease to have effect.

The provisions of Regulations 12, 18 and 19 of the Traffic Signs Regulations 2002 (Part I of SI 2002/3113, "the 2002 Regulations") shall apply to the authorised signs A to D and F in the same manner as they apply to the sign to diagram 670 in Schedule 2 to those Regulations.

The provisions of Regulations 12 and 31 of the 2002 Regulations shall apply to the authorised markings G and H in the same manner as they apply to the road marking to diagram 1065 in Schedule 6 to those Regulations.



Department  
for Transport

GT50/050/0027

This authorisation replaces those listed in the attached Schedule numbered  
GT50/050/0027-3 which are hereby revoked.

Dated: 24 November 2015

Signed by authority of the Secretary of State



.....  
A Delegated Official of the Department for Transport

CERTIFIED TRUE COPY



24/11/2015  
DEPARTMENT FOR TRANSPORT



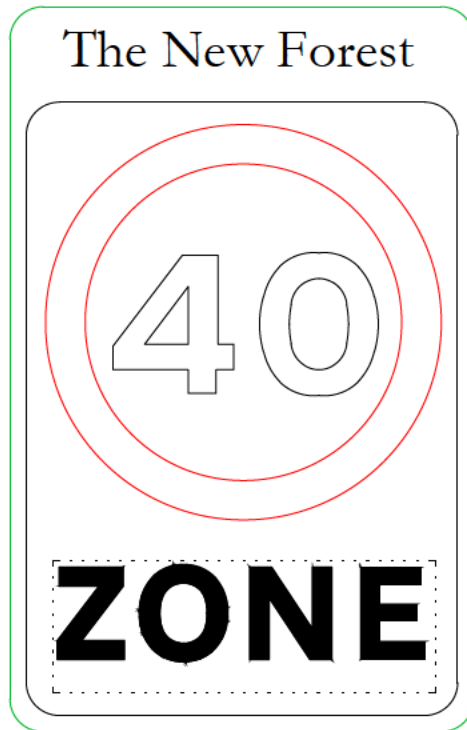

Type A

NOTES

- 1 CONSTRUCTION
- 1.1 Material: Class RA2 (12899 - 1:2007)
- 2 DIMENSIONS
- 2.1 Overall height: 1100mm.
- 2.2 Overall width: 700mm.
- 2.3 Header Panel: 150mm high.
- 2.4 Border: 25mm wide.
- 2.5 Speed limit: 600mm diameter.
- 2.6 Distance between Header Panel and Speed limit: 40mm.
- 2.7 "The New Forest": Albertus type face, x-ht 37.5mm, 50mm above bottom of Header Panel.
- 2.8 "ZONE": Transport Heavy, x-ht 100mm, 85mm above bottom border.
- 2.9 Area: 0.77 sq.m
- 3 COLOUR
- 3.1 Speed limit to TSRGD 2002 (As amended) Diagram 670.
- 3.2 Header panel and border: Brunswick Green.
- 3.3 Background: White.
- 3.4 "The New Forest": White.
- 3.5 "ZONE": Black.

© CROWN COPYRIGHT AND DATABASE RIGHTS 2014.  
ALL RIGHTS RESERVED, HCC 100019180

CLIENT <b>HAMPSHIRE COUNTY COUNCIL</b> ECONOMY, TRANSPORT AND ENVIRONMENT DEPARTMENT STRATEGIC TRANSPORT				CONSULTANT  <b>Hampshire</b> County Council <small>STUART JARVIS BSc DipTP FCITP MRTPE DIRECTOR OF ECONOMY, TRANSPORT &amp; ENVIRONMENT</small>		DESIGNER AN CAD AN CHECKED BB APPROVED MW		SCHEME <b>NEW FOREST</b> <b>SPEED LIMITS</b>		DRAWING TITLE <b>ZONE ENTRY SIGN</b> (TYPE A)	
REV	AMENDMENTS	DATE	CAD	CHKD	APPD	SCALE @ A3	DATE	SHEET NUMBER	DRAWING NUMBER	REV	
						NTS	15.10.2014	1- OF -7	TM/NEW FOREST/2014_15/02		



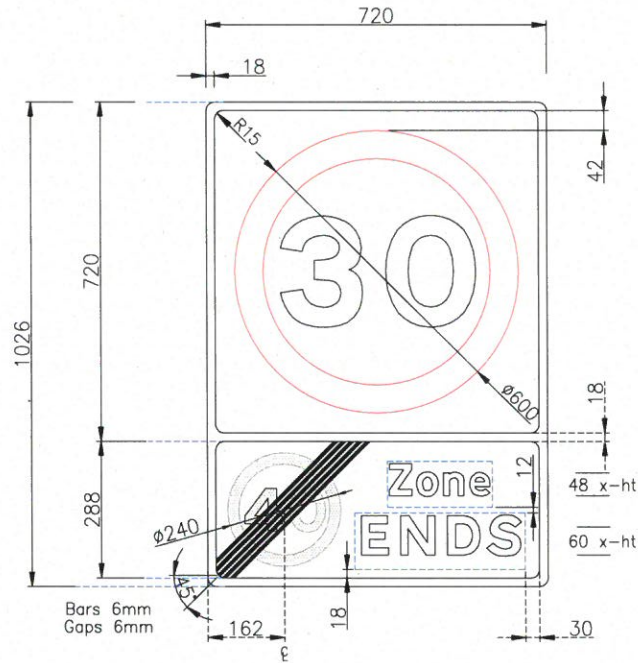

Type C

NOTES

- 1 CONSTRUCTION
- 1.1 Material: Class RA2 (12899 - 1:2007)
- 2 DIMENSIONS
- 2.1 Overall height: 1026mm.
- 2.2 Overall width: 720mm.
- 2.3 Border and Divider: 18mm.
- 2.4 Speed Limit Roundel: 600mm diameter.
- 2.5 Distance between Upper Border and Speed Limit Roundel: 42mm.
- 2.6 Distance between Speed Limit Roundel and Divider: 42mm.
- 2.7 "40" Roundel: 240mm diameter.
- 2.8 Distance between "40" Roundel and Lower Border: 24mm.
- 2.9 "Zone": Transport Heavy 48 x ht.
- 2.10 "ENDS": Transport Heavy 60 x ht.
- 2.11 Area: 0.74 sq.m
- 3 COLOURS
- 3.1 Speed Limit Roundel to TSRGD 2002 (As amended) Diagram 670.
- 3.2 Background: White.
- 3.3 Legend, Cancellation Bars, Border and Divider: Black.
- 3.4 Legend in lower panel: Black.
- 3.5 Numerals and Roundel in lower panel: Grey.

FOR  
INFORMATION  
ONLY

© CROWN COPYRIGHT AND DATABASE RIGHTS 2014.  
ALL RIGHTS RESERVED. MCC 100019180

	CLIENT <b>HAMPSHIRE COUNTY COUNCIL</b> ECONOMY, TRANSPORT AND ENVIRONMENT DEPARTMENT STRATEGIC TRANSPORT	CONSULTANT <b>Hampshire</b> County Council <small>STUART JARVIS BS: Dg/TP FCHT MR/TP DIRECTOR OF ECONOMY, TRANSPORT &amp; ENVIRONMENT</small>	DESIGNER AN CAD AN CHECKED MW APPROVED MS	SCHEME <b>NEW FOREST</b> <b>SPEED LIMITS</b>	DRAWING TITLE <b>ZONE EXIT TO 30MPH SPEED LIMIT</b> (TYPE C)														
<table border="1" style="width: 100%; border-collapse: collapse;"> <tr> <td style="width: 15%;">A</td> <td style="width: 45%;">ISSUING MODIFIED FOLLOWING CORRESPONDENCE WITH DPT.</td> <td style="width: 10%;">15.11.2014</td> <td style="width: 10%;">JH</td> <td style="width: 10%;">MS</td> <td style="width: 10%;">MS</td> </tr> <tr> <td>REV</td> <td>AMENDMENTS</td> <td>DATE</td> <td>CAD</td> <td>CHKD</td> <td>APPR</td> </tr> </table>	A	ISSUING MODIFIED FOLLOWING CORRESPONDENCE WITH DPT.	15.11.2014	JH	MS	MS	REV	AMENDMENTS	DATE	CAD	CHKD	APPR			JOB NO. SCALE @ A3 NTS	DATE 15.10.2014	SHEET NUMBER 1- OF -1	DRAWING NUMBER TM/NEW FOREST/2014_15/02	REV A
A	ISSUING MODIFIED FOLLOWING CORRESPONDENCE WITH DPT.	15.11.2014	JH	MS	MS														
REV	AMENDMENTS	DATE	CAD	CHKD	APPR														

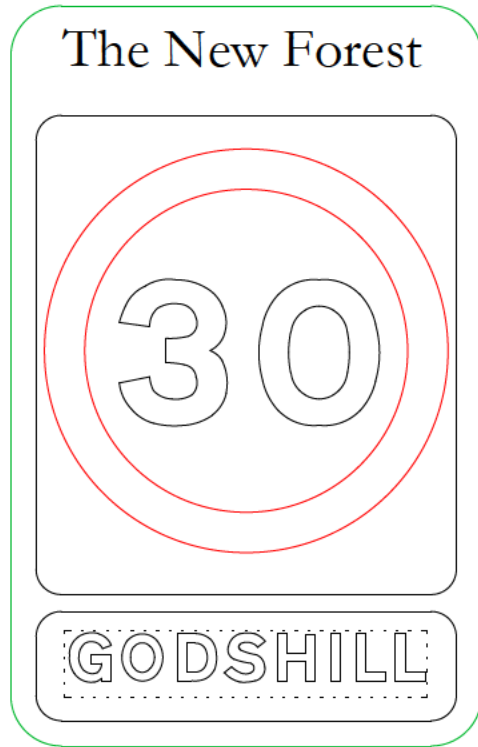

Type D

NOTES

- 1 CONSTRUCTION
- 1.1 Material: Class RA2 (12899 - 1:2007)
- 2 DIMENSIONS
- 2.1 Overall height: 1100mm.
- 2.2 Overall width: 700mm.
- 2.3 Header Panel: 150mm high.
- 2.4 Speed Limit Roundel: 600mm diameter.
- 2.5 Distance between Header Panel and Speed Limit Roundel: 78mm.
- 2.6 "The New Forest": Albertus type face, x-ht 37.5m
- 2.7 Village Name: Transport Heavy, x-ht to suit.
- 2.8 Area: 0.77 sq.m
- 3 COLOUR
- 3.1 Speed limit roundel to TSRGD 2002 (As amended) Diagram 670.
- 3.2 Border, Divider and Header Panel: Brunswick Green.
- 3.3 Background: White.
- 3.4 "The New Forest": White.
- 3.5 Village Name: Black.

© CROWN COPYRIGHT AND DATABASE RIGHTS 2014.  
ALL RIGHTS RESERVED, HCC 100019180

CLIENT <b>HAMPSHIRE COUNTY COUNCIL</b> ECONOMY, TRANSPORT AND ENVIRONMENT DEPARTMENT STRATEGIC TRANSPORT		CONSULTANT  <b>Hampshire</b> County Council <small>STUART JARVIS BSc DipTP FCITP MRTPE DIRECTOR OF ECONOMY, TRANSPORT &amp; ENVIRONMENT</small>		DESIGNER AN CAD AN CHECKED BB APPROVED MW		SCHEME <b>NEW FOREST</b> <b>SPEED LIMITS</b>		DRAWING TITLE <b>30MPH TERMINAL SIGN</b> <b>WITH VILLAGE NAMEPLATE (TYPE D)</b>	
REV	AMENDMENTS	DATE	CAD	CHKD	APPD	SCALE @ A3	DATE	SHEET NUMBER	DRAWING NUMBER
						NTS	15.10.2014	4- OF -7	TM/NEW FOREST/2014_15/02



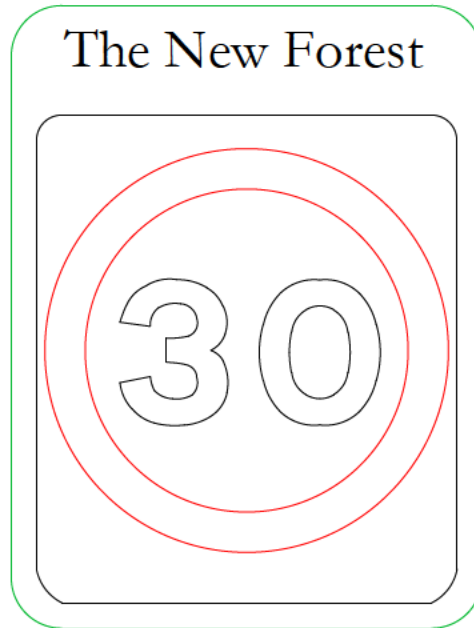

Type F

NOTES

- 1 CONSTRUCTION
- 1.1 Material: Class RA2 (12899 - 1:2007)
- 2 DIMENSIONS
- 2.1 Overall height: 925mm.
- 2.2 Overall width: 700mm.
- 2.3 Header Panel: 150mm high.
- 2.4 Speed Limit Roundel: 600mm diameter.
- 2.5 Distance between Header Panel and Speed Limit Roundel: 78mm.
- 2.6 "The New Forest": Albertus type face, x-ht 37.5m
- 2.7 Area: 0.65 sq.m
- 3 COLOUR
- 3.1 Speed limit roundel to TSRGD 2002 (As amended) Diagram 670.
- 3.2 Border and Top Panel: Brunswick Green.
- 3.3 Background: White.
- 3.4 "The New Forest": White.

© CROWN COPYRIGHT AND DATABASE RIGHTS 2014.  
ALL RIGHTS RESERVED, HCC 100019180

CLIENT <b>HAMPSHIRE COUNTY COUNCIL</b> ECONOMY, TRANSPORT AND ENVIRONMENT DEPARTMENT STRATEGIC TRANSPORT				CONSULTANT  <b>Hampshire</b> County Council <small>STUART JARVIS BSc DipTP FCIBT MRTPE DIRECTOR OF ECONOMY, TRANSPORT &amp; ENVIRONMENT</small>		DESIGNER AN CAD AN CHECKED BB APPROVED MW		SCHEME <b>NEW FOREST</b> <b>SPEED LIMITS</b>		DRAWING TITLE <b>PROPOSED TERMINAL SIGN</b> (TYPE F)	
REV	AMENDMENTS	DATE	CAD	CHKD	APPD	SCALE @ A3	DATE	SHEET NUMBER	DRAWING NUMBER	REV	
						NTS	15.10.2014	5- OF -7	TM/NEW FOREST/2014_15/02		

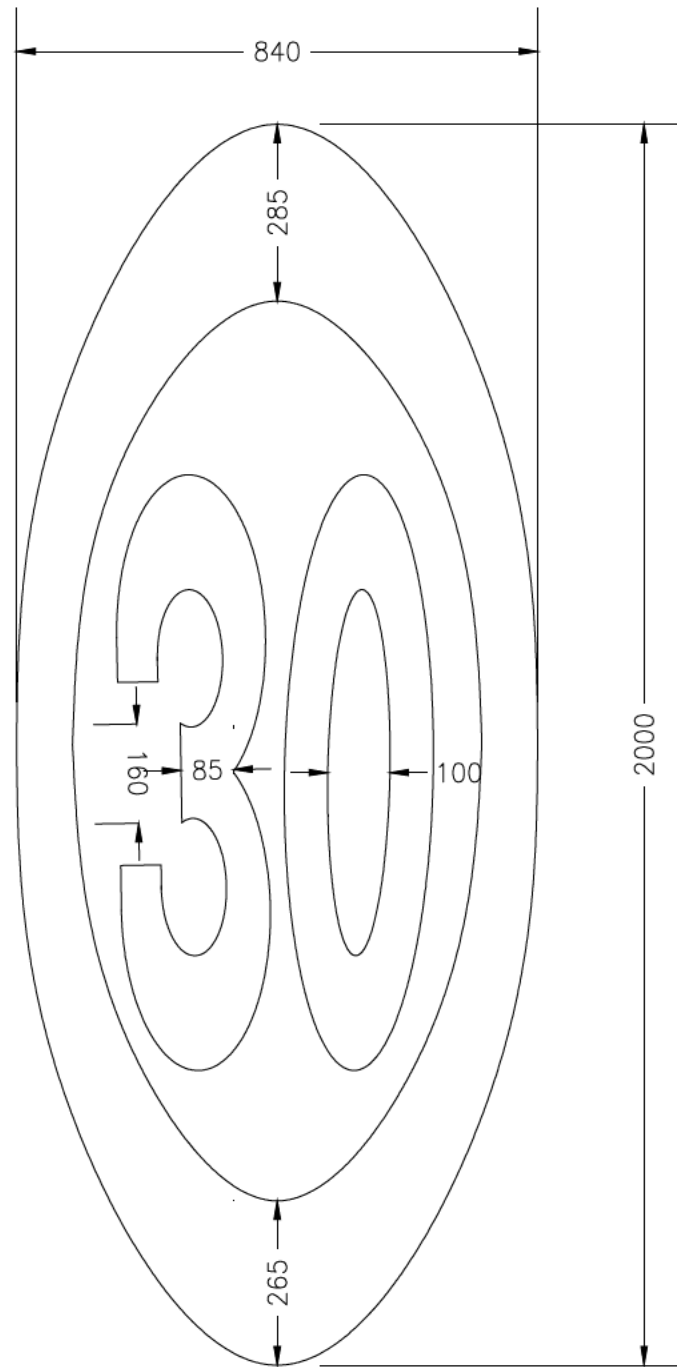

### NOTES

- 1 All dimensions in millimetres.
- 2 Colour of road marking shall be white.
- 3 Road marking shall be Class A thermoplastic material, incorporating synthetic resins only, supplied and laid in accordance with BS EN 1436.

RM1

© CROWN COPYRIGHT AND DATABASE RIGHTS 2014.  
ALL RIGHTS RESERVED, HCC 100019180

CLIENT <b>HAMPSHIRE COUNTY COUNCIL</b> ECONOMY, TRANSPORT AND ENVIRONMENT DEPARTMENT STRATEGIC TRANSPORT		CONSULTANT  <b>Hampshire</b> County Council <small>STUART JARVIS BSc DipTP FCIT MRTPE DIRECTOR OF ECONOMY, TRANSPORT &amp; ENVIRONMENT</small>		DESIGNER AN CAD AN CHECKED BB APPROVED MW		SCHEME NEW FOREST SPEED LIMITS		DRAWING TITLE 30MPH SPEED LIMIT ROAD MARKING		
REV	AMENDMENTS	DATE	CAD	CHKD	APPD	SCALE @ A3	DATE	SHEET NUMBER	DRAWING NUMBER	REV
						NTS	15.10.2014	6-OF-7	TM/NEW FOREST/2014_15/02	

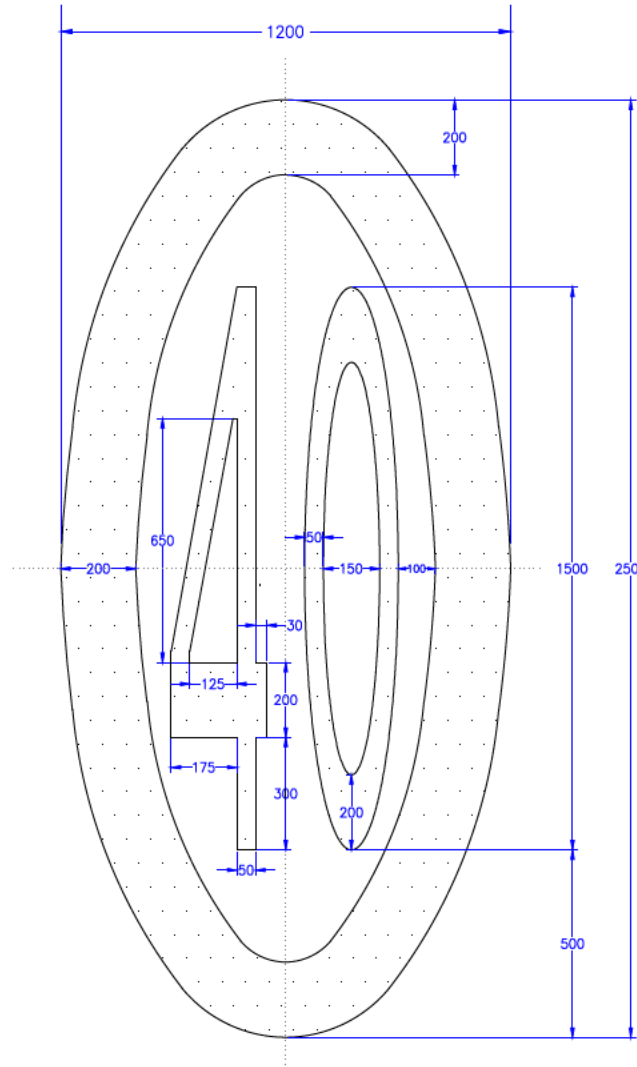

**NOTES**

- 1 All dimensions in millimetres.
- 2 Colour of road marking to be BS 381C Number 310 (Primrose).
- 3 Road marking shall be Class A thermoplastic material, incorporating synthetic resins only, supplied and laid in accordance with BS EN 1436.

RM2

© CROWN COPYRIGHT AND DATABASE RIGHTS 2014.  
ALL RIGHTS RESERVED, HCC 100019180

CLIENT <b>HAMPSHIRE COUNTY COUNCIL</b> ECONOMY, TRANSPORT AND ENVIRONMENT DEPARTMENT STRATEGIC TRANSPORT				CONSULTANT  <b>Hampshire</b> County Council <small>STUART JARVIS BSc DipTP FCIBT MRTPE DIRECTOR OF ECONOMY, TRANSPORT &amp; ENVIRONMENT</small>		DESIGNER AN CAD AN CHECKED BB APPROVED MW		SCHEME NEW FOREST SPEED LIMITS		DRAWING TITLE 40MPH SPEED LIMIT ROAD MARKING	
REV	AMENDMENTS	DATE	CAD	CHKD	APPD	APPROVED	SCALE @ A3 NTS	DATE 15.10.2014	SHEET NUMBER 7-OF-7	DRAWING NUMBER TM/NEW FOREST/2014_15/02	REV

HCC REF:	LOCATION (As stated –	AUTHORISATION OF:	DRAWING NO.	SIGNED (DFT)	DATE
1.	The New Forest, Hampshire – various locations 40mph Zone	- Erection of Traffic Signs Authorisations 1990 Traffic Sign ('The New Forest 40 Zone' Terminal Sign) Traffic Sign ('The New Forest 40 Zone' Terminal Sign) Traffic Sign (40mph - 900mm Diameter) Road Marking (Primrose yellow '40' roundel) Traffic Sign ('40 Zone Ends' Terminal sign) Traffic Sign ('30/ 40 Zone Ends' Terminal sign)	Drawing 1 Drawing 2 Drawing 3 Drawing 4 Drawing 5 Drawing 6	P Martin	16-Mar-1990
2.	The New Forest, Hampshire – B3078 40mph Zone - Amendment	- Authorisation of Traffic Signs Road marking	GT 46/51/05-3	Roger	09-Nov-1990
3.	The New Forest - various locations 40mph Zone	- Special Directions for the placing of Authorised Traffic Signs 1992 - Erection of Traffic Signs Authorisation 1992 Traffic Sign (40 Zone Terminal Sign) Traffic Sign (30/ 40 Zone Ends Terminal) Traffic Sign (NSL/ 40 Zone Ends Terminal) Traffic Sign (40 repeater -300mm diameter) Traffic Sign (40 repeater -450mm diameter) Traffic Sign (40) Road marking ('40' Roundel)	N/a  Sign Ref A (Schedule 2) Sign Ref B (Schedule 2) Sign Ref C (Schedule 2) Sign Ref D (Schedule 2) Sign Ref E (Schedule 2) Sign Ref F (Schedule 2) Sign Ref G (Schedule 2)	P Martin P Martin	05-Jun-1992 05-Jun-1992
4.	The New Forest 40mph Zone (North) – Amendment	- Special Directions for the placing of Authorised Traffic Signs 1994		P H Martin	23-Jun-1994
5.	The New Forest – various locations 40mph Zone	- Special Directions for the placing of Authorised Traffic (Repeater) Signs 1996 - Road Marking '40 Roundel' (Yellow)	N/a TS1834	R M Kimber R M Kimber	06-Sep-1996 06-Sep-1996
6.	Extension to the New Forest 40mph Zone, 1997	- Road Markings ('40' Roundel)	TS1834	A Waddams	09-May-1997
7.	Beaulieu, New Forest, Hampshire	- Traffic Signs and Special Direction (30mph Zone sign & 30 Roundel)	TS2295 TS315	A Waddams	06-May-1998
8.	The New Forest – various locations 40mph Zone	- Speed Limit Sign (40 Zone Terminal) - Speed Limit Sign (NSL/ 40 Zone Ends) - Speed Limit Sign (30/ 40 Zone Ends) - Speed Limit Sign (30 Zone Terminal) - Speed Limit Sign (30 Zone Terminal) - Road Marking (40 Roundel, yellow) - Road Marking (30 Roundel, white)	Drawing No.1 Drawing No. 2 Drawing No. 3 Drawing No. 4 Drawing No. 5 Drawing No. 6 Drawing No. 7	A E Waddams A E Waddams A E Waddams A E Waddams A E Waddams A E Waddams A E Waddams	15-Jan-2001 15-Jan-2001 15-Jan-2001 15-Jan-2001 15-Jan-2001 15-Jan-2001 15-Jan-2001

Continued....

HCC REF:	LOCATION	AUTHORISATION OF:	DRAWING NO.	SIGNED (DFT)	DATE
9.	Neacroft & Godwincroft, Hampshire	-Road Markings (30 Roundel)	TS2315/A	A Waddams	18-Mar-2002
		-Speed Limit Signs (30mph Zone)	Drawing No.1	A E Waddams	18-Mar-2002
10.	Tiptoe, Hampshire	-Speed Limit Signs (30mph Zone)	Drawing No.1	A E Waddams	15-Mar-2002
		-Speed Limit Signs (40mph Zone)	TS1834	A E Waddams	18-Mar-2002
		- Road Markings (30 Roundel)	TS2315/A	A E Waddams	15-Mar-2002
11.	Mead End, Hampshire	-Road Markings (30 Roundel)	TS2315/A	A Waddams	18-Mar-2002
		-Speed Limit Signs (30mph Zone)	Drawing No.1	A E Waddams	18-Mar-2002
12.	Boldre & Pilley, Hampshire	-Speed Limit Signs (30mph Zone)	TS 3217	A Waddams	18-Mar-2002
		-Speed Limit Signs (40mph Zone)	TS 3217	A Waddams	18-Mar-2002
		- Road Markings (30 Roundel)	TS 2315/A	A Waddams	18-Mar-2002
13.	Minstead, Hampshire	-Speed Limit Signs (30mph Zone)	Drawing No.1	A E Waddams	18-Mar-2002
		- Road Markings (40 Roundel)	TS1834	A E Waddams	18-Mar-2002
		- Road Markings (30 Roundel)	TS2315/A	A E Waddams	18-Mar-2002
14.	Brockenhurst, Hampshire	-Speed Limit Signs (30mph Zone)	TS2544	Joshua Fox	07-Aug-2008
		-Speed Limit Signs (30mph Zone Ends)	TS1976	Joshua Fox	07-Aug-2008
		- Road Markings (30 Roundel)	TS2315/A	Joshua Fox	07-Aug-2008
15.	New Forest - Bramshaw, Hampshire	-Speed limit signs (40mph zone terminal)	TS1774	Joshua Fox	17-Sep-2008
		-Speed limit signs (30mph zone terminal)	227552/EQ/13/40/A	Joshua Fox	17-Sep-2008
		-Road markings (30 Roundel)	TS2315/A	Joshua Fox	17-Sep-2008
16.	New Forest – Woodgreen, Hampshire	-Speed limit signs (30mph Terminal)	227552/EQ/17/40B	Joshua Fox	17-Sep-2008
		-Speed limit signs (40mph Terminal)	TS1774	Joshua Fox	17-Sep-2008
		-Speed limit signs ('30' roundel)	TS2315/A	Joshua Fox	17-Sep-2008
17.	New Forest – Godshill, Hampshire	-Speed limit Signs (40mph Terminal)	TS1774	Joshua Fox	17-Sep-2008
		-Speed limit Signs(30mph Terminal)	227552/EQ/16/41	Joshua Fox	17-Sep-2008
		-Road Markings ('30' roundel)	TS2315/A	Joshua Fox	17-Sep-2008
18.	New Forest – Breamore, Hampshire	-Speed limit Signs (40 Zone Terminal)	TS1774	Joshua Fox	17-Sep-2008
		-Speed limit Signs(30mph Terminal)	227552/EQ/14/41	Joshua Fox	17-Sep-2008
		-Road Markings ('30' roundel)	TS2315/A	Joshua Fox	17-Sep-2008
19.	New Forest – Brook, Hampshire	-Speed limit Signs (40 Zone Terminal)	TS1774	Joshua Fox	17-Sep-2008
		-Speed limit Signs(30mph Terminal)	227552/EQ/13/40C	Joshua Fox	17-Sep-2008
		-Road Markings ('30' roundel)	TS2315/A	Joshua Fox	17-Sep-2008

Continued.....

HCC REF:	LOCATION	AUTHORISATION OF:	DRAWING NO.	SIGNED (DFT)	DATE
20.	New Forest – Ashurst, Hampshire	-Speed limit Signs (40 Zone Terminal) -Speed limit Signs(40/ 40 zone ends terminal)	TS1774 227552/EQ/219	Joshua Fox Joshua Fox	17-Sep-2008 17-Sep-2008
21.	New Forest – Ripley, Hampshire	-Speed limit Signs(30mph Terminal)	227552/EQ/219	Joshua Fox	17-Sep-2008
22.	New Forest – Avon, Hampshire	-Speed limit Signs(40/ 40 zone ends Terminal)	227552/EQ/219	Joshua Fox	17-Sep-2008
23.	New Forest – Fritham, Hampshire	-Speed limit Signs (40 Zone Terminal) -Speed limit Signs(30mph Terminal) -Road Markings ('30' roundel)	TS1774 227552/EQ/13/40E TS2315/A	Joshua Fox Joshua Fox Joshua Fox	17-Sep-2008 17-Sep-2008 17-Sep-2008
24.	New Forest – Hale, Hampshire	-Speed limit Signs (NSL/ Zone Ends) -Speed limit Signs (40 zone Terminal) -Speed limit Signs (30 zone Terminal) -Road Markings (30 roundel)	227552/EQ/221 TS1774 227552/EQ/17/42 TS2315/A	Joshua Fox Joshua Fox Joshua Fox Joshua Fox	17-Sep-2008 17-Sep-2008 17-Sep-2008 17-Sep-2008
25.	Marchwood, New Forest	- Speed Limit Signs- 30mph zone terminal	227552/IG92/601	Kristine Kleidt-Gorton	09-Nov-2009
26.	East Boldre, New Forest	- Speed Limit Signs- 30mph zone terminal	227552/IG99/601	Kristine Kleidt0Gorton	09-Nov-2009
27.	Hyde, New Forest	- Speed Limit Signs- 30mph zone terminal	227552/IG96/601	Kristine Kleidt0Gorton	09-Nov-2009
28.	Ibsley, New Forest	- Speed Limit Signs- 30mph zone terminal	227552/IG97/601	Kristine Kleidt0Gorton	09-Nov-2009
29.	Various Locations, New Forest	- Speed Limit Signs- 40mph zone terminal - Speed Limit Signs- 30mph zone terminal - Speed Limit Signs- 30 roundel	227552/IG99/602 227552/IG/316 Dia 1065	Kristine Kleidt0Gorton Kristine Kleidt0Gorton Kristine Kleidt0Gorton	09-Nov-2009 09-Nov-2009 09-Nov-2009
30	Various Locations, New Forest	- Speed Limit Signs- 40 mph terminal - Speed Limit Signs- 30 mph terminal - Speed Limit Signs- 40 mph Zone Ends - Speed Limit Signs- 30 mph Zone Ends - Road Marking (40 roundel) - Road Marking (30 roundel)	GT50/050/0026-2 GT50/050/0026-2 GT50/050/0026-2 GT50/050/0026-2 GT50/050/0026-2 GT50/050/0026-2	John Bennett John Bennett John Bennett John Bennett John Bennett John Bennett	23-Oct-2014 23-Oct-2014 23-Oct-2014 23-Oct-2014 23-Oct-2014 23-Oct-2014