



Department
for Transport

Road Traffic Regulation Act 1984 Sections 64 and 65

Authorisation of traffic signs and special directions

Accessible transcript

Secretary of State for Transport's traffic authorisation of signs/markings for the purpose of warning road users of the proximity of school children in Hampshire.

The following pages contain a copy of the text from the Secretary of State for Transport's traffic authorisation regarding the above sign/marking.

A scanned copy of the signed authorisation and supporting signs/markings from the application are appended to this letter. The supporting material is submitted to the Department for Transport by a third party. You should refer to the party involved for accessible copies of the supporting material.



**ROAD TRAFFIC REGULATION ACT 1984 – SECTIONS 64 AND 65
AUTHORISATION OF TRAFFIC SIGNS AND SPECIAL DIRECTIONS**

The Secretary of State for Transport, in exercise of his powers under Sections 64 and 65 of the Road Traffic Regulation Act 1984, and of all other powers enabling him in that behalf, for the purpose of warning road users of the proximity of school children in Hampshire, hereby:-

1. authorises the placing at appropriate sites on roads for which Hampshire County Council is the traffic authority of a traffic sign consisting of a road marking (hereinafter referred to as “the authorised marking”) conforming as to size, colour and character with that shown on the attached drawing numbered NP 545RM; and
2. directs that the authorised marking shall only be used with the sign shown in diagram 545 in Schedule 2, Part 2, Item 25 of the Traffic Signs Regulations 2016 (Part 1 of S.I. 2016/362, “the 2016 Regulations”); and
3. directs, without prejudice to any statutory provision to the like effect, that it is a condition of this authorisation that the placing of the authorised marking at or near the said sites shall continue to have effect only until such day as may be appointed by one month’s notice given by the Secretary of State in writing to the traffic authority for the removal or alteration of the authorised marking and on that day the said authorisation shall, without prejudice to the giving of any further authorisation or direction, cease to have effect.



The provisions of Regulations 7, 9 and 10 of the 2016 Regulations shall apply to the authorised marking in the same manner as they apply to the road marking to diagram 1057 in Schedule 11, Part 4, Item 28 of those Regulations.

Dated *20 March 2020*

Signed by authority of the Secretary of State

.....

A Delegated Official of the Department for Transport

**Scanned copy of the
signed authorisation
follows**



**ROAD TRAFFIC REGULATION ACT 1984 – SECTIONS 64 AND 65
AUTHORISATION OF TRAFFIC SIGNS AND SPECIAL DIRECTIONS**

The Secretary of State for Transport, in exercise of his powers under Sections 64 and 65 of the Road Traffic Regulation Act 1984, and of all other powers enabling him in that behalf, for the purpose of warning road users of the proximity of school children in Hampshire, hereby:-

1. authorises the placing at appropriate sites on roads for which Hampshire County Council is the traffic authority of a traffic sign consisting of a road marking (hereinafter referred to as “the authorised marking”) conforming as to size, colour and character with that shown on the attached drawing numbered NP 545RM; and
2. directs that the authorised marking shall only be used with the sign shown in diagram 545 in Schedule 2, Part 2, Item 25 of the Traffic Signs Regulations 2016 (Part 1 of S.I. 2016/362, “the 2016 Regulations”); and
3. directs, without prejudice to any statutory provision to the like effect, that it is a condition of this authorisation that the placing of the authorised marking at or near the said sites shall continue to have effect only until such day as may be appointed by one month’s notice given by the Secretary of State in writing to the traffic authority for the removal or alteration of the authorised marking and on that day the said authorisation shall, without prejudice to the giving of any further authorisation or direction, cease to have effect.



The provisions of Regulations 7, 9 and 10 of the 2016 Regulations shall apply to the authorised marking in the same manner as they apply to the road marking to diagram 1057 in Schedule 11, Part 4, Item 28 of those Regulations.

Dated *20 March 2020*

Signed by authority of the Secretary of State

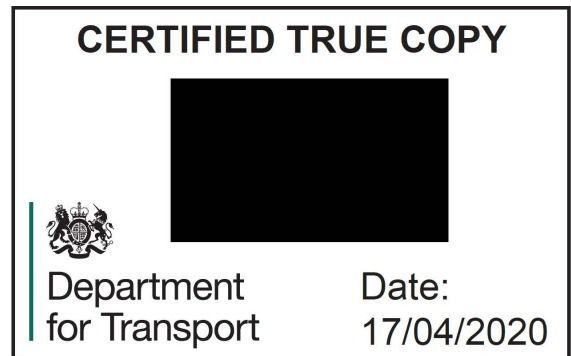

.....
A Delegated Official of the Department for Transport

Drawing No.
NP 545RM

Related Drawings
P 500 & P545

© CROWN COPYRIGHT

- NOTES:—
1. Marking is based on drawing P 545 elongated vertically by a factor of 1600/560.
 2. The tile outline does not form part of the marking.
 3. All 3030mm x 1200mm sign dimensions shall be varied proportionally for the other triangle sizes.
 4. Dimensions, other than those shown in grid divisions, are in millimetres.

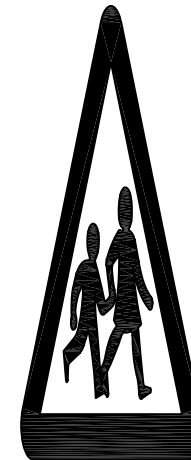
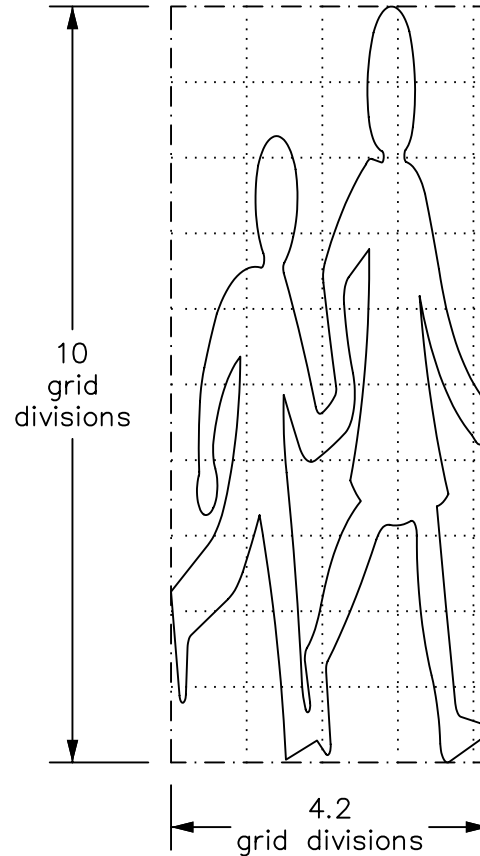
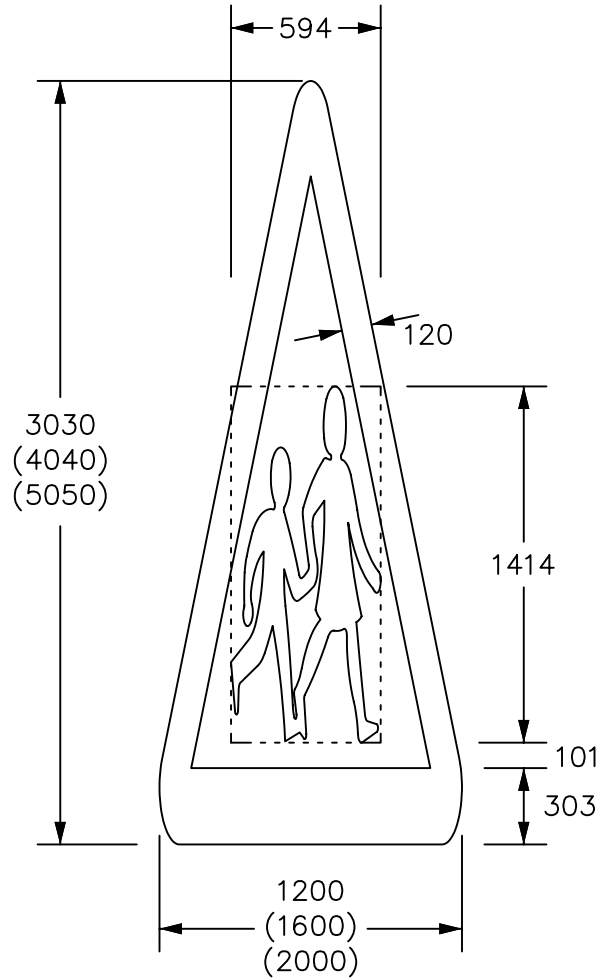

NP545RM

Before using this drawing, confirm that it has not been superseded.

Department for
Transport

Title: Road Marking
CHILDREN
(going to or from school)
or playground ahead

Issue: Date:
A: 3.2.98
C: 19.3.03
D: 29.12.03

Drawn by: R.M.
Approved by: R.M.

Dimensions:
SEE
NOTE 4

Drawing No.
NP 545RM