



Department  
for Transport

## Road Traffic Regulation Act 1984 Sections 64 and 65

### Authorisation of traffic signs and special directions

#### Accessible transcript

Secretary of State for Transport's traffic authorisation of signs/markings for the purpose of informing road users of a mandatory variable speed limit on all purpose trunk roads for which Highways England is the traffic authority.

The following pages contain a copy of the text from the Secretary of State for Transport's traffic authorisation regarding the above sign/marking.

A scanned copy of the signed authorisation and supporting signs/markings from the application are appended to this letter. The supporting material is submitted to the Department for Transport by a third party. You should refer to the party involved for accessible copies of the supporting material.



**ROAD TRAFFIC REGULATION ACT 1984 – SECTIONS 64 AND 65**  
**AUTHORISATION OF TRAFFIC SIGNS AND SPECIAL DIRECTIONS**

The Secretary of State for Transport, in exercise of his powers under Section 64 and 65 of the Road Traffic Regulation Act 1984, and all other powers enabling him in that behalf for the purpose of informing road users of a mandatory variable speed limit on all purpose trunk roads for which Highways England is the traffic authority, hereby:

1. authorises the erection at appropriate sites on the said roads of a traffic sign (hereinafter referred to as “the authorised sign A”) conforming as to size, colour and character with that referenced NP 409 in the attached set of drawings save that (i) the x-height may be varied as indicated and (ii) the legend may include, or a legend may be added for, the name, and logo, of the enforcement authority; and
2. authorises the erection at appropriate sites on the said roads, of a traffic sign (hereinafter referred to as “the authorised sign B”) conforming as to size, colour and character with that referenced NP 409.1 in the attached set of drawings save that (i) the x-height may be varied as indicated and (ii) the legend may include, or a legend may be added for, the name, and logo, of the enforcement authority; and
3. directs that the numerals indicating the maximum speed limit on the authorised sign B may be varied as appropriate and must conform as to size, colour and character with that shown in diagram 670 in Schedule 10, Part 2, Item 1 to the Traffic Signs Regulations and General Directions 2016 (Part 1 of S.I. 2016/362, “the 2016 Regulations”); and
4. directs that the authorised signs A and B shall only be used as and when required to advise road users of the operation of an approved system of variable speed limit enforcement; and



5. directs that it is a condition of this authorisation that the authorised signs A and B may only be placed to indicate the effect of a corresponding Traffic Regulation Order; and
  
6. directs, without prejudice to any statutory provision to the like effect, that it is a condition of this authorisation that the erection of the authorised signs A and B at or near the said sites shall continue to have effect only until such day as may be appointed by one month's notice given by the Secretary of State in writing to the traffic authority for the removal or alteration of the authorised signs A and B and on that day the said authorisation shall, without prejudice to the giving of any further authorisation or direction, cease to have effect.

The provisions of Regulations 5, 7, 8 and 11 of the 2016 Regulations shall apply to the authorised signs A and B in the same manner as they apply to the sign shown in diagram 880 in Schedule 11, Part 2, Item 64 to those Regulations.

Dated *28 April 2020*

Signed by authority of the Secretary of State

.....  
A Delegated Official of the Department for Transport



Department  
for Transport

**SCANNED  
AUTHORISATION AND  
MAPS / DRAWINGS  
FOLLOW**



**ROAD TRAFFIC REGULATION ACT 1984 – SECTIONS 64 AND 65**  
**AUTHORISATION OF TRAFFIC SIGNS AND SPECIAL DIRECTIONS**

The Secretary of State for Transport, in exercise of his powers under Section 64 and 65 of the Road Traffic Regulation Act 1984, and all other powers enabling him in that behalf for the purpose of informing road users of a mandatory variable speed limit on all purpose trunk roads for which Highways England is the traffic authority, hereby:

1. authorises the erection at appropriate sites on the said roads of a traffic sign (hereinafter referred to as “the authorised sign A”) conforming as to size, colour and character with that referenced NP 409 in the attached set of drawings save that (i) the x-height may be varied as indicated and (ii) the legend may include, or a legend may be added for, the name, and logo, of the enforcement authority; and
2. authorises the erection at appropriate sites on the said roads, of a traffic sign (hereinafter referred to as “the authorised sign B”) conforming as to size, colour and character with that referenced NP 409.1 in the attached set of drawings save that (i) the x-height may be varied as indicated and (ii) the legend may include, or a legend may be added for, the name, and logo, of the enforcement authority; and
3. directs that the numerals indicating the maximum speed limit on the authorised sign B may be varied as appropriate and must conform as to size, colour and character with that shown in diagram 670 in Schedule 10, Part 2, Item 1 to the Traffic Signs Regulations and General Directions 2016 (Part 1 of S.I. 2016/362, “the 2016 Regulations”); and
4. directs that the authorised signs A and B shall only be used as and when required to advise road users of the operation of an approved system of variable speed limit enforcement; and



5. directs that it is a condition of this authorisation that the authorised signs A and B may only be placed to indicate the effect of a corresponding Traffic Regulation Order; and
6. directs, without prejudice to any statutory provision to the like effect, that it is a condition of this authorisation that the erection of the authorised signs A and B at or near the said sites shall continue to have effect only until such day as may be appointed by one month's notice given by the Secretary of State in writing to the traffic authority for the removal or alteration of the authorised signs A and B and on that day the said authorisation shall, without prejudice to the giving of any further authorisation or direction, cease to have effect.

The provisions of Regulations 5, 7, 8 and 11 of the 2016 Regulations shall apply to the authorised signs A and B in the same manner as they apply to the sign shown in diagram 880 in Schedule 11, Part 2, Item 64 to those Regulations.

Dated *28 April 2020*

Signed by authority of the Secretary of State



.....  
A Delegated Official of the Department for Transport

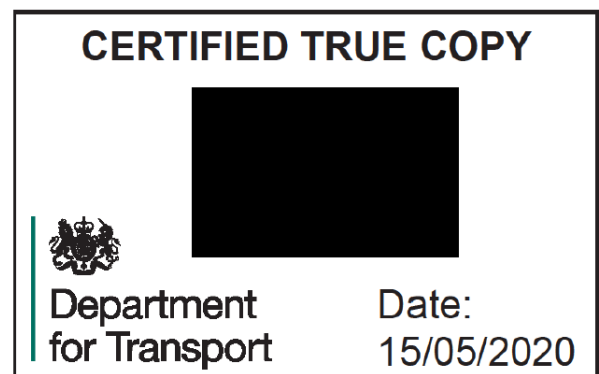



Department  
for Transport

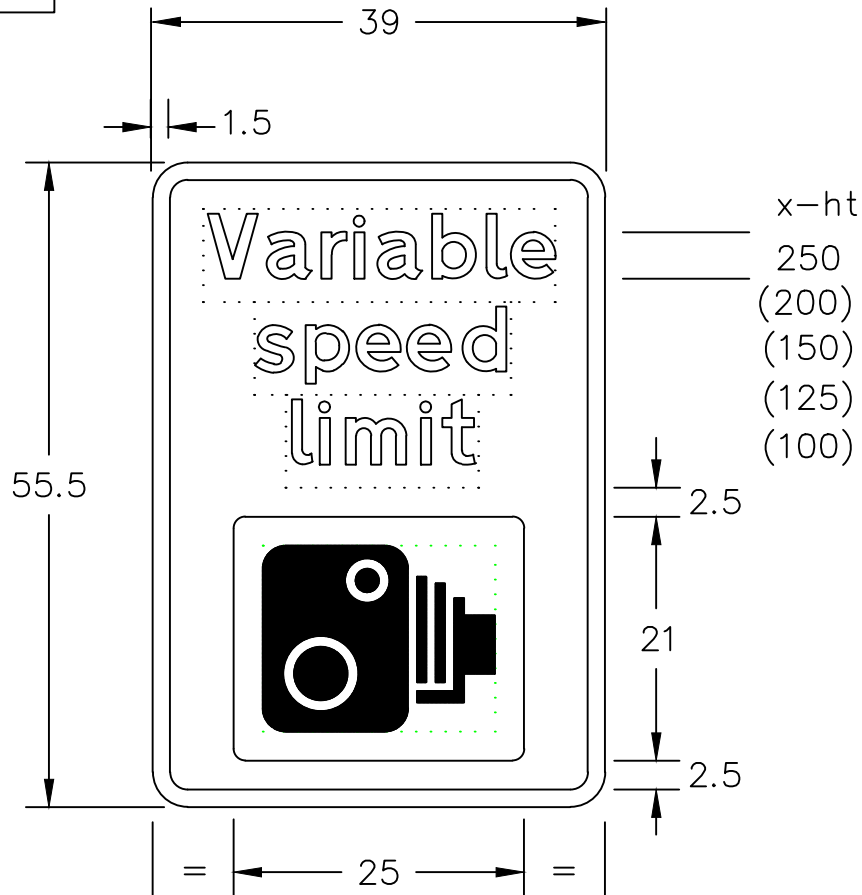

NOTES

© CROWN COPYRIGHT

1. The legend is from the Transport Medium alphabet at the x-heights shown.
2. The camera symbol details are shown on drawing S 58.
3. The tile outlines do not form part of the sign.
4. COLOURS: – BS EN 12899-1  
 Legend, Borders & Symbol Tile..... WHITE  
 Background..... BLUE  
 Symbol..... BLACK
5. DIMENSIONS: – x-heights are in millimetres, other dimensions in stroke widths (4sw = x-ht)

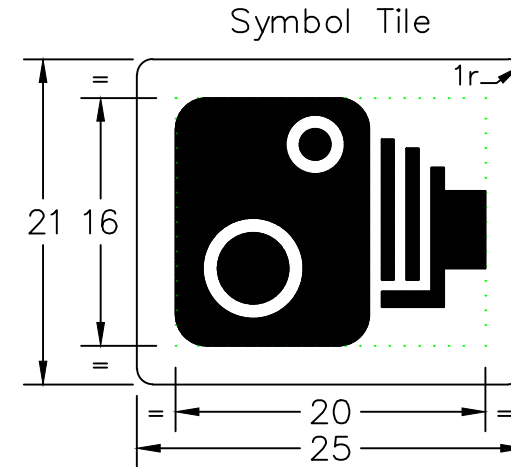

NP409

Before using this drawing, confirm that it has not been superseded.

<p>Title: Informatory Sign</p> <p>VARIABLE SPEED LIMIT START</p>	<p>Issue: Date:</p> <p>A: 20.1.94</p> <p>C: 28.1.10</p> <p>D: 26.2.13</p>	<p>Drawn by: A.K.</p> <p>Approved by: J.B.</p>	<p>Related drawings: S 58</p>	<p>Dimensions: SEE NOTE 5</p>	<p>Drawing No. NP 409</p>
------------------------------------------------------------------	---------------------------------------------------------------------------	------------------------------------------------	-------------------------------	-------------------------------	---------------------------

**Variable  
speed  
limit**

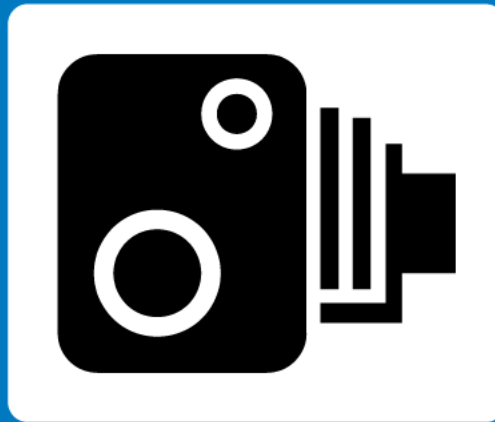





Department  
for Transport

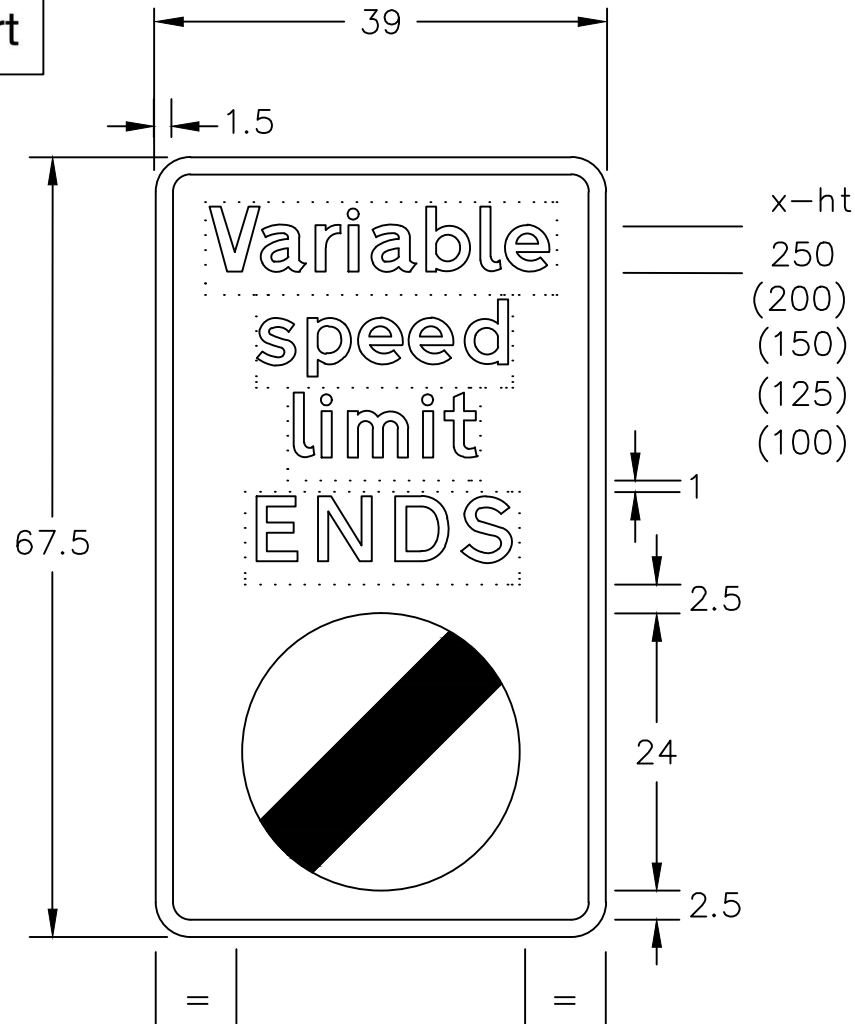

NOTES

© CROWN COPYRIGHT

1. The legend is from the Transport Medium alphabet at the x-heights shown.
2. The roundels illustrated are proportional to those shown on drawings P 671 and P 670.
3. The tile outlines do not form part of the sign.
4. COLOURS: – BS EN 12899-1  
 Legend and Borders..... WHITE  
 Background..... BLUE  
 Roundels.....see appropriate drawings
5. DIMENSIONS: – x-heights are in millimetres, other dimensions in stroke widths (4sw = x-ht)

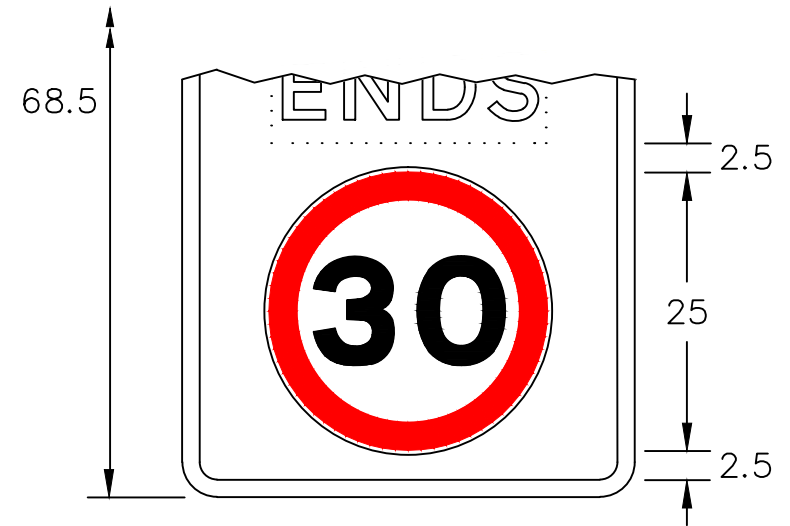

NP409x1

Before using this drawing, confirm that it has not been superseded.

<p>Title: Informatory Sign VARIABLE SPEED LIMIT END WITH REMINDER OF PERMANENT LIMIT</p>	<p>Issue: Date: A: 20.1.94 C: 28.1.10 D: 26.2.13</p>	<p>Drawn by: A.K. Approved by: J.B.</p>	<p>Related drawings : P 671 &amp; P 670</p>	<p>Dimensions : SEE NOTE 5</p>	<p>Drawing No. NP 409.1</p>
--------------------------------------------------------------------------------------------------	------------------------------------------------------------------	---------------------------------------------	-------------------------------------------------	------------------------------------	---------------------------------

**Variable  
speed  
limit  
ENDS**



**Variable  
speed  
limit  
ENDS**



Millimetres

0 10

DO NOT SCALE

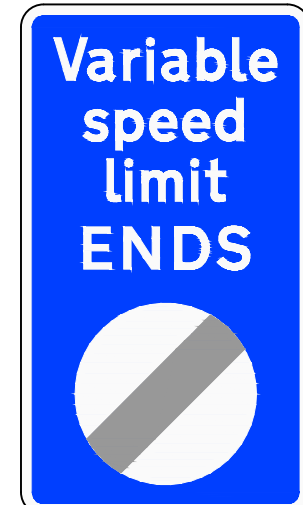
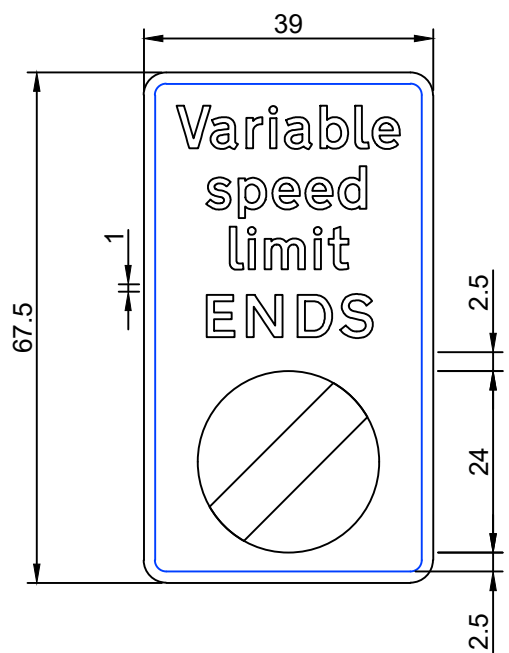
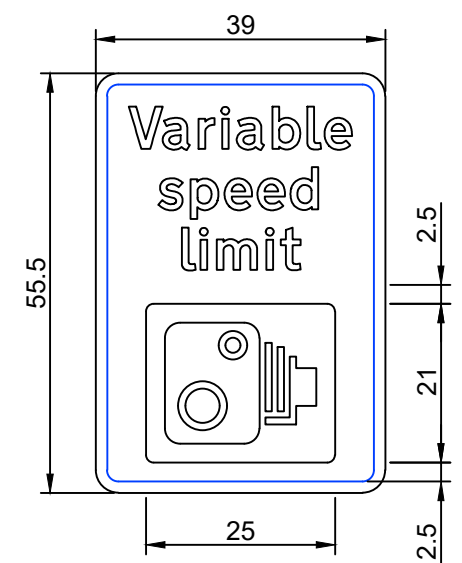
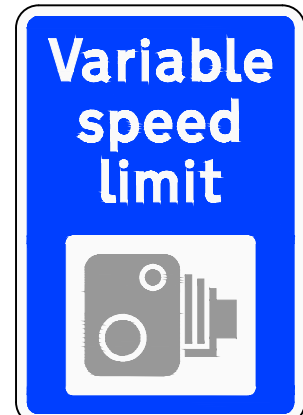
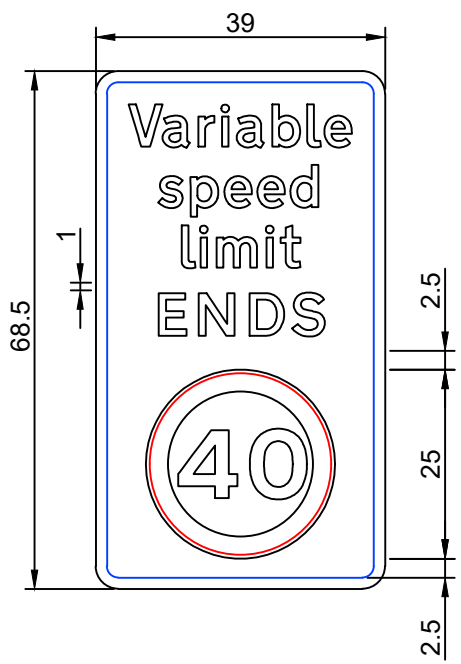
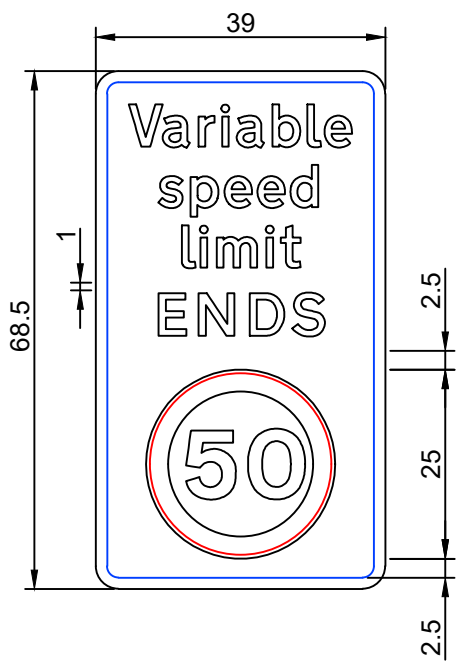

X height to be 100mm, 125mm, 150mm 200mm or 250mm

Rev.	Date	Description	By	Chk'd	App'd
P01	18/05/20	FIRST ISSUE	SS	SD	AH

Drawing Status	FOR INFORMATION	Suitability	S2	Project Title	A14 CAMBRIDGE TO HUNTINGDON				
				Drawing Title	VMSL NON-PRESCRIBED SIGN DETAILS				
Scale	NTS	Drawn	SS	Checked	SD	Approved	AH	Authorised	AH
Original Size	A3	Date	18/05/20	Date	18/05/20	Date	18/05/20	Date	18/05/20
Drawing Number	Project		Originator	Volume	Project Ref. No.				
	HA528983 - ACJV - HSN - SG_XX - SK - C - 0004				P01				
Location	Type	Role	Number						