



Department
for Transport

Road Traffic Regulation Act 1984 Sections 64 and 65

Authorisation of traffic signs and special directions

Accessible transcript

Secretary of State for Transport's traffic authorisation of signs/markings for the purpose of informing road users of a left turn prohibition at the A205 Cavendish Road junction with A24 Clapham Common Southside in London.

The following pages contain a copy of the text from the Secretary of State for Transport's traffic authorisation regarding the above sign/marking.

A scanned copy of the signed authorisation and supporting signs/markings from the application are appended to this letter. The supporting material is submitted to the Department for Transport by a third party. You should refer to the party involved for accessible copies of the supporting material.



**ROAD TRAFFIC REGULATION ACT 1984 – SECTIONS 64 AND 65
AUTHORISATION OF TRAFFIC SIGNS AND SPECIAL DIRECTIONS**

The Secretary of State for Transport, in exercise of his powers under Sections 64 and 65 of the Road Traffic Regulation Act 1984, and of all other powers enabling him in that behalf, for the purpose of informing road users of a left turn prohibition at the A205 Cavendish Road junction with A24 Clapham Common Southside in London, hereby:-

1. authorises the erection at or within 5 metres of the sites shown schematically on the attached plan numbered GT50/139/0179-1 for which Transport for London is the traffic authority of a traffic sign consisting of a plate (hereinafter referred to as “the authorised plate”) conforming as to size, colour and character with that shown as “AUTH PLATE” on the attached drawing numbered GT50/139/0179-2 save that the x-height may be varied; and
2. directs that the authorised plate shall only be used with the sign to diagram 613 in Schedule 3, Part 2, Item 8 and with the sign shown in Schedule 12, Part 20, Item 19 of the Traffic Signs Regulations 2016 (Part 1 of S.I. 2016/362, “the 2016 Regulations”); and
3. directs that it is a condition of this authorisation that the authorised plate may be placed only to indicate the effect of a corresponding Traffic Regulation Order; and
4. directs, without prejudice to any statutory provision to the like effect, that it is a condition of this authorisation that the erection of the authorised plate at or near the said site shall continue to have effect only until such day as may be appointed by one month’s notice given by the Secretary of State in writing to the traffic authority for the removal or alteration of the authorised plate and on that day the said authorisation shall, without prejudice to the giving of any further authorisation or direction, cease to have effect.



The provisions of Regulations 7, 8 and 11 of the 2016 Regulations shall apply to the authorised plate in the same manner as they apply to the plate described in Schedule 3, Part 3, Item 3 of those Regulations.

Dated *30 April 2020*

Signed by authority of the Secretary of State

.....

A Delegated Official of the Department for Transport



Department
for Transport

**SCANNED
AUTHORISATION AND
MAPS / DRAWINGS
FOLLOW**



**ROAD TRAFFIC REGULATION ACT 1984 – SECTIONS 64 AND 65
AUTHORISATION OF TRAFFIC SIGNS AND SPECIAL DIRECTIONS**

The Secretary of State for Transport, in exercise of his powers under Sections 64 and 65 of the Road Traffic Regulation Act 1984, and of all other powers enabling him in that behalf, for the purpose of informing road users of a left turn prohibition at the A205 Cavendish Road junction with A24 Clapham Common Southside in London, hereby:-

1. authorises the erection at or within 5 metres of the sites shown schematically on the attached plan numbered GT50/139/0179-1 for which Transport for London is the traffic authority of a traffic sign consisting of a plate (hereinafter referred to as “the authorised plate”) conforming as to size, colour and character with that shown as “AUTH PLATE” on the attached drawing numbered GT50/139/0179-2 save that the x-height may be varied; and
2. directs that the authorised plate shall only be used with the sign to diagram 613 in Schedule 3, Part 2, Item 8 and with the sign shown in Schedule 12, Part 20, Item 19 of the Traffic Signs Regulations 2016 (Part 1 of S.I. 2016/362, “the 2016 Regulations”); and
3. directs that it is a condition of this authorisation that the authorised plate may be placed only to indicate the effect of a corresponding Traffic Regulation Order; and
4. directs, without prejudice to any statutory provision to the like effect, that it is a condition of this authorisation that the erection of the authorised plate at or near the said site shall continue to have effect only until such day as may be appointed by one month’s notice given by the Secretary of State in writing to the traffic authority for the removal or alteration of the authorised plate and on that day the said authorisation shall, without prejudice to the giving of any further authorisation or direction, cease to have effect.



The provisions of Regulations 7, 8 and 11 of the 2016 Regulations shall apply to the authorised plate in the same manner as they apply to the plate described in Schedule 3, Part 3, Item 3 of those Regulations.



Dated *30 April 2020*

Signed by authority of the Secretary of State

[Redacted signature]

.....

A Delegated Official of the Department for Transport

CERTIFIED TRUE COPY	
	
	
Department for Transport	Date: 15/05/2020

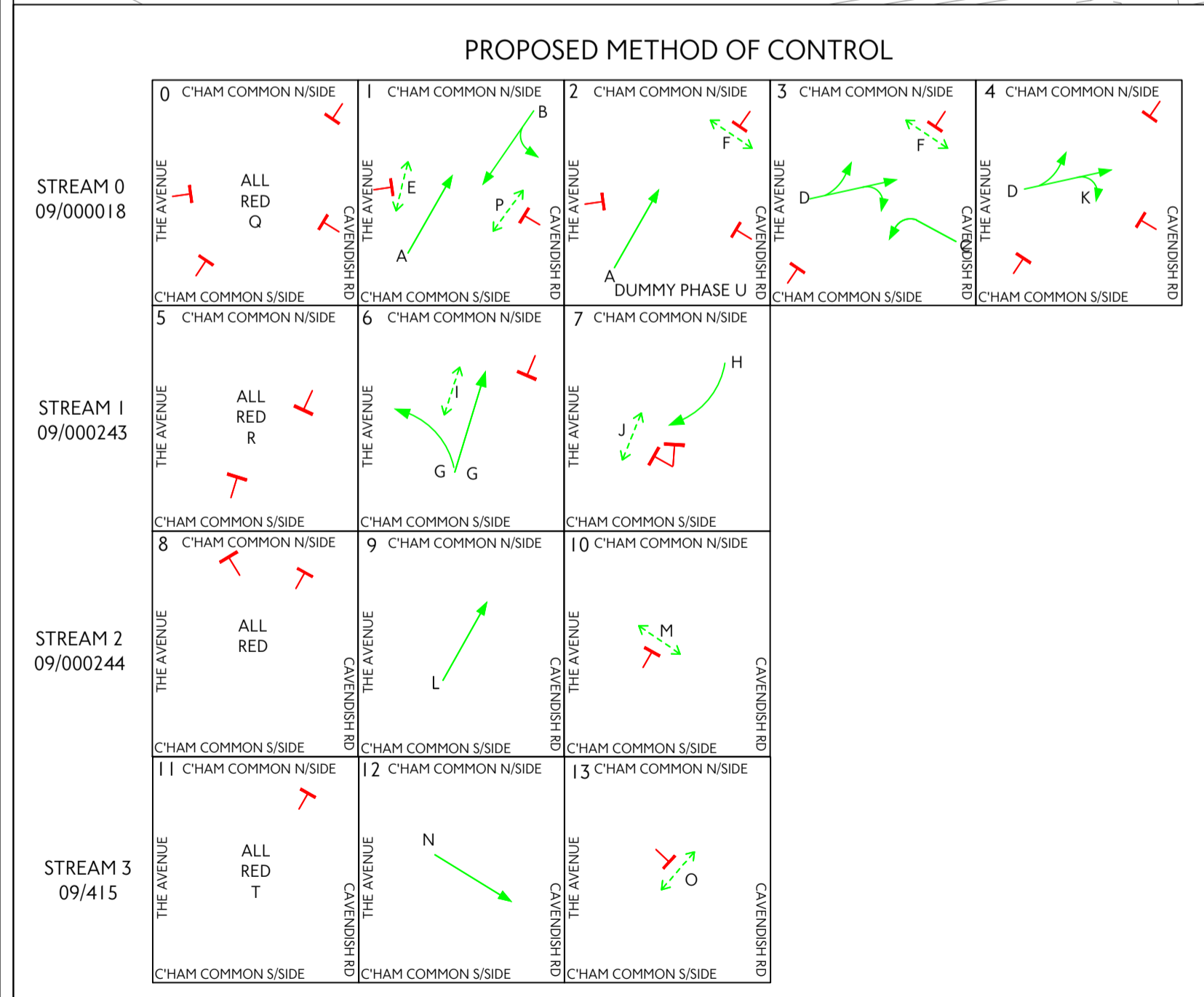
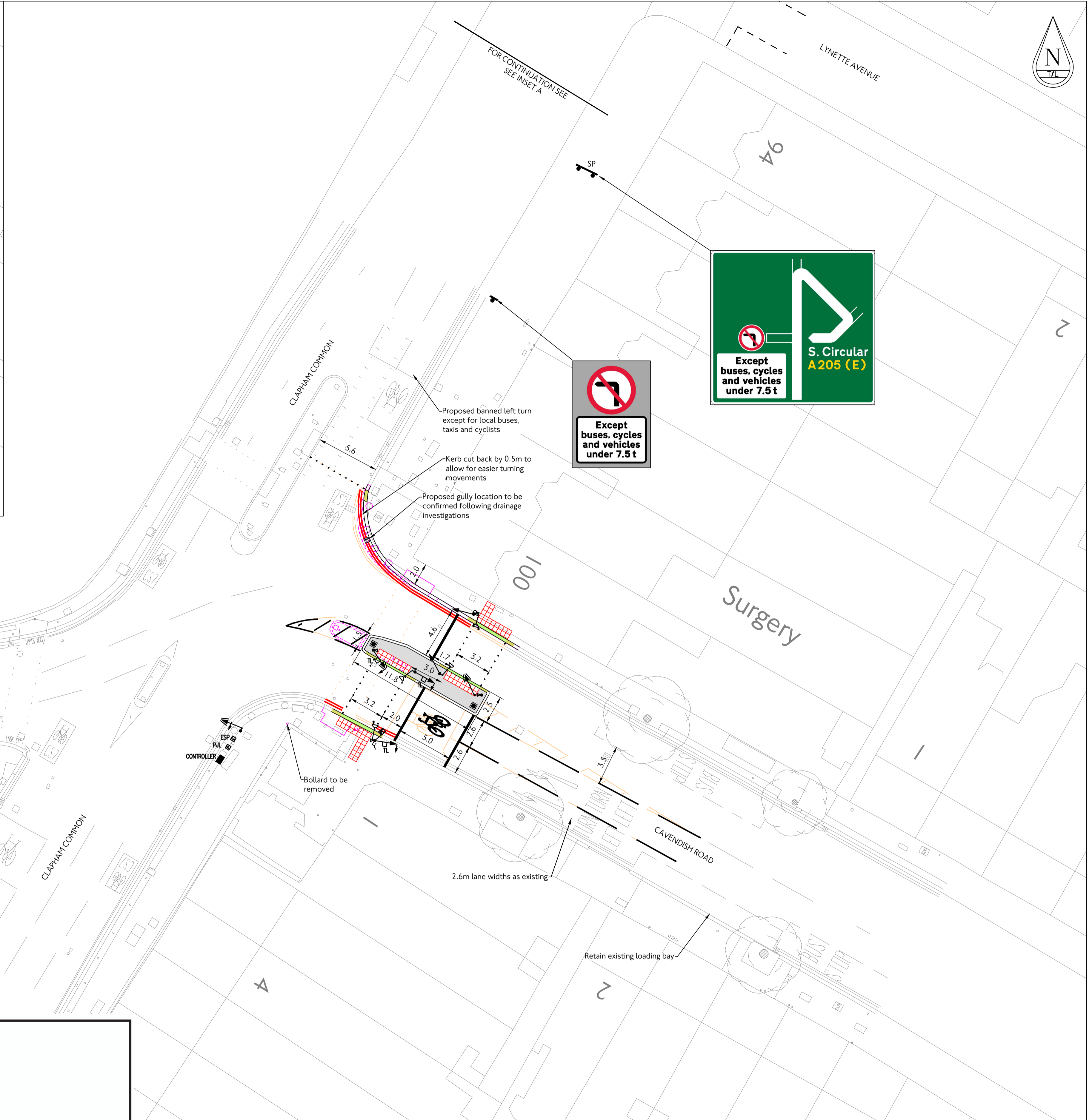
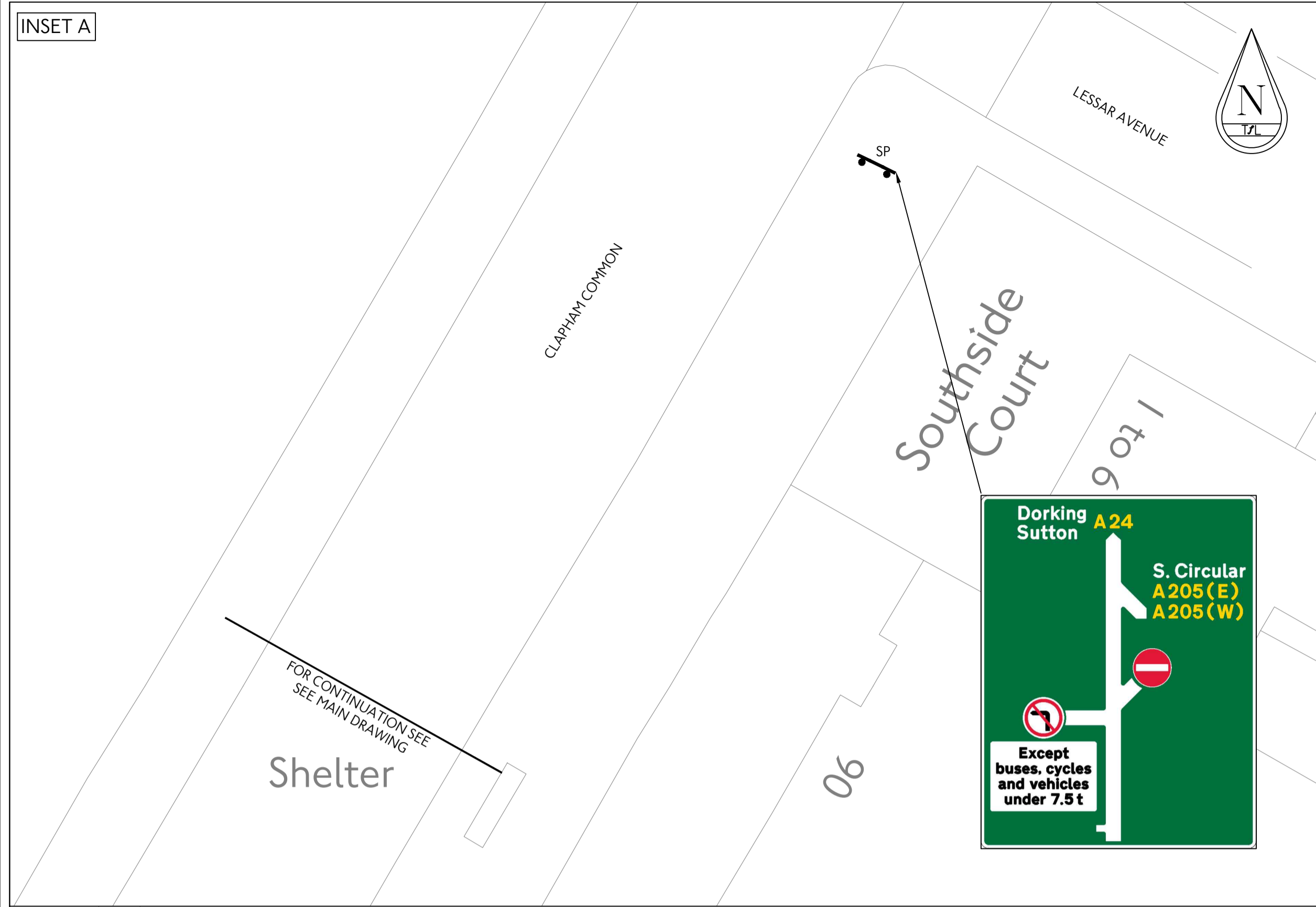

Department for Transport

Date: 30 April 2020

Number: GT50/139/0179-1

LEGEND

- Proposed road marking - White
- Proposed road marking - Red
- Proposed cycle logo (TSRGD 1057) (2750h)
- Proposed kerb
- Proposed dropped kerb
- Proposed transition kerb
- B • Proposed bollard
- SP • Proposed sign and post
- Proposed Kerbed Island
- G □ Proposed gully
- IB ■ Proposed illuminated bollard - keep left
- Proposed traffic signal
- Proposed tactile paving - red
- Road markings to be removed
- Kerb to be removed
- Bollard to be removed/relocated
- Existing traffic signal to be removed/relocated
- Footway/paving To Be Removed

rev	date	details	dwn	chk	app
POS	10.02.20	Design freeze for consultation	PF	HW	MB

PO	date	details	dwn	chk	app
P04	15.11.19	Minor changes to design and MOC	NC	HW	
P03	08.01.19	Banned left into Cavendish Road		HW	
P02	02.11.18	Issued for comment	AS	-	-
P01	14.08.17	Issued for comment	JA	JA	HW

borough

scheme

LB of Lambeth
Cavendish Rd
Pedestrian Crossing
Concept Design

Transport for London
Surface Transport

Road Space Management
Outcomes Design Engineering

Palestra
197 Blackfriars Road
London
SE1 8NJ

date	scale	dwn	chk	app	sheet no
AUG 17	1:200 @ A1	JA	JA	HW	0001 OF 0001

drawing No: **P05**

3005403-RSM-PRD-09-DR-TE-01-0001

© Crown copyright and database rights 2020 Ordnance Survey 100039971

FILE REF: \\onelondon.tf.local\shared\MYP\TDE\Scheme Information\Central Area\TC017 A24 Inner Corridor\TC_017_3005403 Cavendish Rd Ped Crossing\06 Drawings\01 WIP\DR\3005403-RSM-PRD-09-DR-TE-01.dwg | USER: Shah Amir (Engineering) | DATE: 2020 Apr 24 1:27



Sign Reference	RS01 - 613
Height	750mm
Width	750mm
Area	0.44 m ²
Material	Class RA2 (12899-1:2007)
Mount Height	2300

← AUTH PLATE

Scheme Ref.	Cavendish Rd Ped Crossing		
Sign Ref.	RS01 - 613 Sub Plate	x-height	75.0
Letter colour	BLACK	SIGN FACE	
Background	WHITE	Width	1090mm
Border	BLACK	Height	730mm
Material	Class RA2 (12899-1:2007)	Area	0.8m ²

Scheme Ref.	Cavendish Rd Ped Crossing		
Sign Ref.	RS01 - 613 Yellow BB	x-height	75.0
Letter colour	N/A	SIGN FACE	
Background	GREY	Width	1200mm
Border	N/A	Height	1640mm
Material	Class RA2 (12899-1:2007)	Area	1.97m ²



Department for Transport

Date: 30 April 2020

Number: GT50/139/0179-2

rev	date	details	dm	chk	app

borough LAMBETH

scheme CAVENDISH RD PED CROSSING RS01

Transport for London
TfL Engineering

Traffic Design Engineering



Palestra
197 Blackfriars Road
London SE1 8NJ

date	scale	dm	chk	app	sheet no
APR 20	N.T.S @ A4	A3	HW	-	0001 OF 0003
suitability	NON-VERIFIED DESIGN			revision	
S0				P.001	
drawing No 3005403-RSM-TSL-09-DR-TE-05-0001					
project	owner	asset	location	type	role

© Crown copyright and database rights 2020 Ordnance Survey 100035971

DRAFT

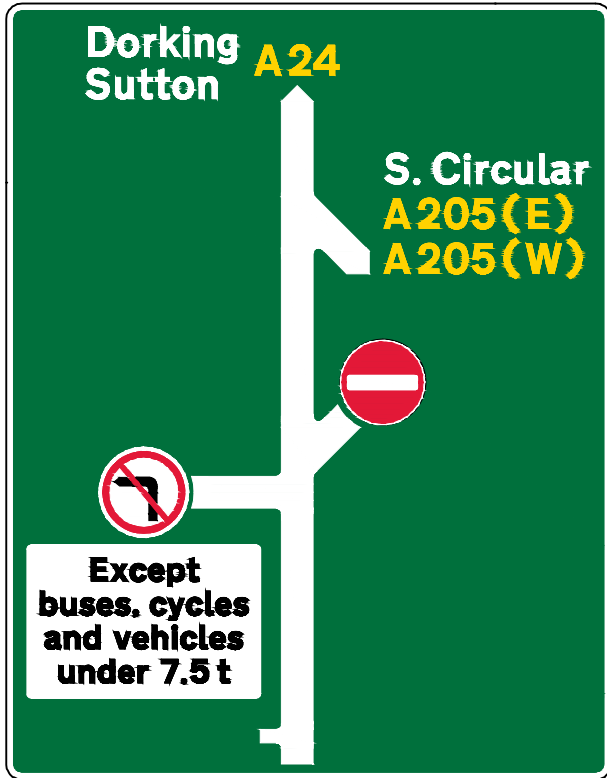
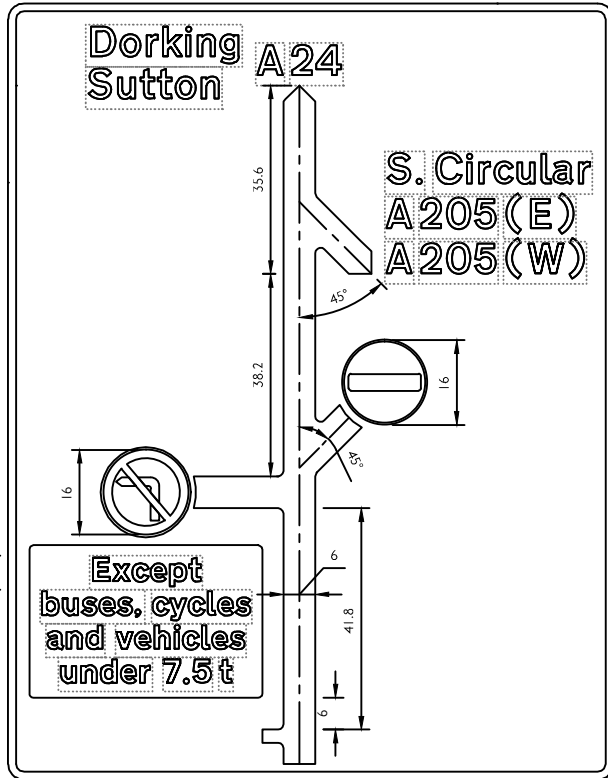

Scheme Ref.	Cavendish Rd Ped Crossing		
Sign Ref.	RS02	x-height	75.0
Letter colour	WHITE	SIGN FACE	
Background	DARK GREEN	Width	2145mm
Border	WHITE	Height	2750mm
Material	Class RA2 (12899-1:2007)	Area	5.89m ²

Scheme Ref.	Cavendish Rd Ped Crossing		
Sign Ref.	RS02	x-height	75.0
Letter colour	WHITE	SIGN FACE	
Background	DARK GREEN	Width	2145mm
Border	WHITE	Height	2750mm
Material	Class RA2 (12899-1:2007)	Area	5.89m ²

rev	date	details	drn	chk	app

borough	LAMBETH				
scheme	CAVENDISH RD PED CROSSING RS02				

Transport for London
TfL Engineering

Traffic Design Engineering

 Palestra
197 Blackfriars Road
London SE1 8NJ

DRAFT

date	scale	drn	chk	app	sheet no
APR 20	NTS @ A4				0002 OF 0003
suitability	NON-VERIFIED DESIGN			revision	
S0				P00.1	
drawing No 3005403-RSM-TSL-09-DR-TE-05-0002					
project	owner	asset	location	type	role

© Crown copyright and database rights 2020 Ordnance Survey 100035971

rev	date	details	drn	chk	app

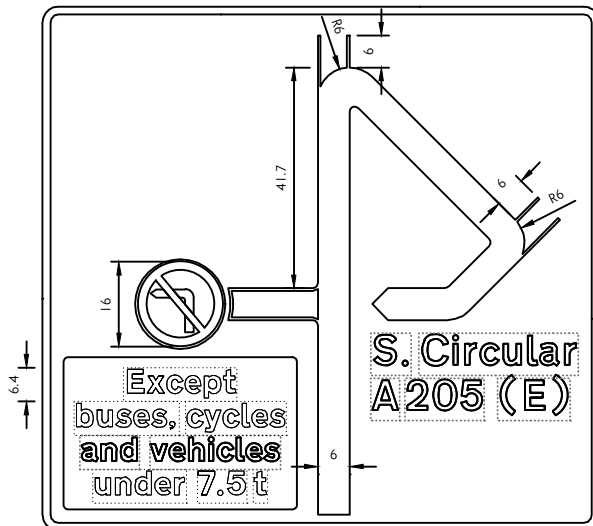

Scheme Ref.		Cavendish Rd Ped Crossing	
Sign Ref.	RS03	x-height	75.0
Letter colour	WHITE	SIGN FACE	
Background	DARK GREEN	Width	1975mm
Border	WHITE	Height	1855mm
Material	Class RA2 (12899-1:2007)	Area	3.66m ²

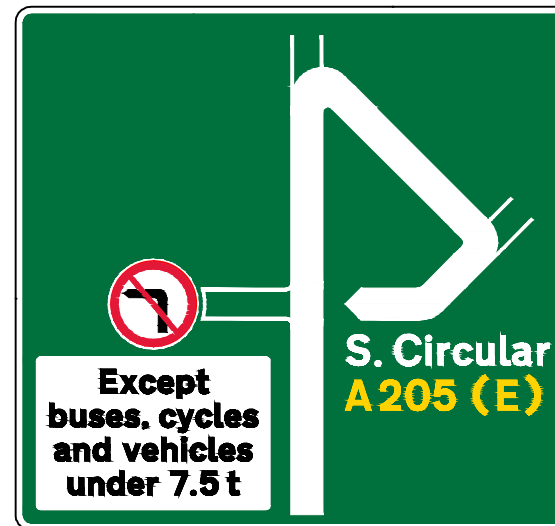

Scheme Ref.		Cavendish Rd Ped Crossing	
Sign Ref.	RS03	x-height	75.0
Letter colour	WHITE	SIGN FACE	
Background	DARK GREEN	Width	1975mm
Border	WHITE	Height	1855mm
Material	Class RA2 (12899-1:2007)	Area	3.66m ²

rev	date	details	drn	chk	app

borough	LAMBETH
scheme	CAVENDISH RD PED CROSSING RS03

Transport for London
TfL Engineering

Traffic Design Engineering

 Palestra
197 Blackfriars Road
London SE1 8NJ

DRAFT

date	scale	drn	chk	app	sheet no
APR 20	NTS @ A4	APP	CHK	APP	0003 OF 0003
suitability	revision			revision	
S0	NON-VERIFIED DESIGN			P00.1	
drawing No					
3005403-RSM-TSL-09-DR-TE-05-0003					
project	owner	asset	location	type	role

© Crown copyright and database rights 2020 Ordnance Survey 100035971

rev	date	details	drn	chk	app