



Department
for Transport

Road Traffic Regulation Act 1984 Sections 64 and 65

Authorisation of traffic signs and special directions

Accessible transcript

Secretary of State for Transport's traffic authorisation of signs/markings for the purpose of warning road users of road works and lane closures on motorway and all-purpose trunk roads (including their slip roads) in England by persons acting on behalf of National Highways, and where National Highways is the traffic authority.

The following pages contain a copy of the text from the Secretary of State for Transport's traffic authorisation regarding the above sign/marking.

A scanned copy of the signed authorisation and supporting signs/markings from the application are appended to this letter. The supporting material is submitted to the Department for Transport by a third party. You should refer to the party involved for accessible copies of the supporting material.



**ROAD TRAFFIC REGULATION ACT 1984 – SECTIONS 64 AND 65
AUTHORISATION OF TRAFFIC SIGNS AND SPECIAL DIRECTIONS**

The Secretary of State for Transport, in exercise of his powers under Sections 64 and 65 of the Road Traffic Regulation Act 1984, and all other powers enabling him in that behalf for the purpose of warning road users of road works and lane closures on motorway and all-purpose trunk roads (including their slip roads) in England by persons acting on behalf of National Highways, and where National Highways is the traffic authority, hereby:-

1. authorises the placing and use on mobile traffic management (MTM) vehicles of a variable message sign (hereinafter referred to as “the authorised sign A”) conforming as to size, colour and character with that referenced as “Aspect A” on the attached drawing numbered GT50/198/0087-1; and
2. authorises the placing and use on MTM vehicles of a variable message sign (hereinafter referred to as “the authorised sign B”) conforming as to size, colour and character with that referenced as “Aspect B” on the attached drawing numbered GT50/198/0087-1; and
3. authorises the placing and use on MTM vehicles of a variable message sign (hereinafter referred to as “the authorised sign C”) conforming as to size, colour and character with that referenced as “Aspect C” on the attached drawing numbered GT50/198/0087-1; and
4. authorises the placing and use on MTM vehicles of a variable message sign (hereinafter referred to as “the authorised sign D”) conforming as to size, colour and character with that referenced as “Aspect D” on the attached drawing numbered GT50/198/0087-1; and
5. authorises the placing and use on mobile traffic management (MTM) vehicles of a variable message sign (hereinafter referred to as “the authorised sign E”)



conforming as to size, colour and character with that referenced as “Aspect A” on the attached drawing numbered GT50/198/0087-2; and

6. authorises the placing and use on MTM vehicles of a variable message sign (hereinafter referred to as “the authorised sign F”) conforming as to size, colour and character with that referenced as “Aspect B” on the attached drawing numbered GT50/198/0087-2; and
7. authorises the placing and use on MTM vehicles of a variable message sign (hereinafter referred to as “the authorised sign G”) conforming as to size, colour and character with that referenced as “Aspect C” on the attached drawing numbered GT50/198/0087-2; and
8. authorises the placing and use on MTM vehicles of a variable message sign (hereinafter referred to as “the authorised sign H”) conforming as to size, colour and character with that referenced as “Aspect D” on the attached drawing numbered GT50/198/0087-2; and
9. directs that the authorised signs A and E shall only be displayed when the MTM vehicle is placed on a live traffic lane on a motorway or all-purpose dual carriageway (including their one way slip roads) and indicates that vehicles must only pass to the left of the MTM vehicle situated in the carriageway; and
10. directs that the authorised signs B and F shall only be displayed when the MTM vehicle is placed on a live traffic lane on a motorway or all-purpose dual carriageway (including their one way slip roads) and indicates that vehicles must only pass to the right of the MTM vehicle situated in the carriageway; and
11. directs that the authorised signs C and G shall only be displayed when the MTM vehicle is placed on the hard shoulder (or any other part of the carriageway which is not a live traffic lane) on a motorway or all-purpose dual carriageway road (including their one way slip roads); and



12. directs that the authorised signs D and H shall only be displayed when the MTM vehicle is placed on a live traffic lane on a single carriageway road; and
13. directs that the Light Emitting Arrow on the authorised signs A, B, E and F shall pulse at a rate of 30 to 50 flashes per minute and that the on-period shall be twice the length of the off-period; and
14. directs that the two light roundels at the top of the of the authorised signs A, B, C, E, F and G shall flash simultaneously. When used with the authorised signs A, B, E and F, the two light roundels shall only flash during the off-period of the Light Emitting Arrow. When used with authorised signs C and G, the two light roundels shall flash at a rate of between 30 to 50 flashes per minute and that the on-period shall be twice the length of the off-period; and
15. directs that the four light roundels on the authorised signs D and H shall flash in vertical pairs and that each roundel shall show an intermittent light at a rate of flashing of not less than 60 nor more than 90 flashes per minute, and in such a manner that the lights of one vertical pair are always shown (on) when the lights of the other vertical pair are not shown (off); and
16. directs that the authorised signs A, B, E and F may be used in place of signs conforming to Diagram 610 in Schedule 13, Part 6, Item 11 or Diagram 7403 in Schedule 13, Part 6, Item 10 to the Traffic Signs Regulations and General Directions 2016 (Part 1 of S.I. 2016/362, “the 2016 Regulations”) where the permanent maximum speed limit is 40 mph or lower; and
17. directs that the authorised signs A, B, E and F may be used in place of signs conforming to Diagram 610 in Schedule 13, Part 6, Item 11 of the 2016 Regulations where the permanent maximum speed limit is over 40 mph; and
18. directs that the authorised signs C, D, G and H may be displayed on a MTM vehicle where the speed limit for the road the vehicle is placed on is the National Speed Limit, or lower; and



19. directs that the authorised signs A to H shall only be used on MTM vehicles which are being used for works, mobile lane closures or mobile carriageway closures as indicated in Chapter 8 of the Traffic Signs Manual (TSM) or for emergency traffic management; and
20. directs that the authorised signs A to H shall be so installed so that the highest part of the sign assembly, including any lights or beacons, when the lightest gross in-service vehicle weight applies, is no greater than 4.98 metres above ground level; and
21. directs that the authorised signs A to H shall only be placed on the road, by personnel trained to do so in accordance with the relevant Sector Scheme and in accordance with any specific equipment, operational, maintenance and monitoring requirements specified by the manufacturer; and
22. directs that when not displaying any authorised sign, the unit shall be off and display a blank grey face; and
23. directs, without prejudice to any statutory provisions to the like effect, that it is a condition of this authorisation that the placing of a MTM vehicle displaying the authorised signs A to H on a road shall continue to have effect only until such day as may be appointed by one month's notice given by the Secretary of State in writing to the traffic authority for the removal or alteration of the authorised signs A to H and on that day the said authorisation shall, without prejudice to the giving of any further authorisation or direction, cease to have effect.

The provisions of Regulations 5 and 7 of the 2016 Regulations shall apply to the authorised signs A to H in the same manner as they apply to the sign shown in Diagram 7403 in Schedule 13, Part 6, Item 10 to those Regulations.



The provisions of Schedule 9, Part 7, Item 9 paragraph 5(e) of the 2016 Regulations shall apply to the authorised signs A, B, E and F in the same manner as they apply to the sign shown in Diagram 7403 in Schedule 13, Part 6, Item 10 of those Regulations.

The provisions of Schedule 13, Part 7, Item 1 of the 2016 Regulations shall apply to the authorised signs A, B, E and F in the same manner as they apply to the sign shown in Diagram 7403 in Schedule 13, Part 6, Item 10 of those Regulations.

The provisions of Schedule 13, Part 12, Item 6(3) of the 2016 Regulations shall apply to the authorised signs A to H.

Dated *05 November 2021*

Signed by authority of the Secretary of State

.....

A Delegated Official of the Department for Transport



Department
for Transport

**SCANNED
AUTHORISATION AND
MAPS / DRAWINGS
FOLLOW**



**ROAD TRAFFIC REGULATION ACT 1984 – SECTIONS 64 AND 65
AUTHORISATION OF TRAFFIC SIGNS AND SPECIAL DIRECTIONS**

The Secretary of State for Transport, in exercise of his powers under Sections 64 and 65 of the Road Traffic Regulation Act 1984, and all other powers enabling him in that behalf for the purpose of warning road users of road works and lane closures on motorway and all-purpose trunk roads (including their slip roads) in England by persons acting on behalf of National Highways, and where National Highways is the traffic authority, hereby:-

1. authorises the placing and use on mobile traffic management (MTM) vehicles of a variable message sign (hereinafter referred to as “the authorised sign A”) conforming as to size, colour and character with that referenced as “Aspect A” on the attached drawing numbered GT50/198/0087-1; and
2. authorises the placing and use on MTM vehicles of a variable message sign (hereinafter referred to as “the authorised sign B”) conforming as to size, colour and character with that referenced as “Aspect B” on the attached drawing numbered GT50/198/0087-1; and
3. authorises the placing and use on MTM vehicles of a variable message sign (hereinafter referred to as “the authorised sign C”) conforming as to size, colour and character with that referenced as “Aspect C” on the attached drawing numbered GT50/198/0087-1; and
4. authorises the placing and use on MTM vehicles of a variable message sign (hereinafter referred to as “the authorised sign D”) conforming as to size, colour and character with that referenced as “Aspect D” on the attached drawing numbered GT50/198/0087-1; and
5. authorises the placing and use on mobile traffic management (MTM) vehicles of a variable message sign (hereinafter referred to as “the authorised sign E”)



conforming as to size, colour and character with that referenced as “Aspect A” on the attached drawing numbered GT50/198/0087-2; and

6. authorises the placing and use on MTM vehicles of a variable message sign (hereinafter referred to as “the authorised sign F”) conforming as to size, colour and character with that referenced as “Aspect B” on the attached drawing numbered GT50/198/0087-2; and
7. authorises the placing and use on MTM vehicles of a variable message sign (hereinafter referred to as “the authorised sign G”) conforming as to size, colour and character with that referenced as “Aspect C” on the attached drawing numbered GT50/198/0087-2; and
8. authorises the placing and use on MTM vehicles of a variable message sign (hereinafter referred to as “the authorised sign H”) conforming as to size, colour and character with that referenced as “Aspect D” on the attached drawing numbered GT50/198/0087-2; and
9. directs that the authorised signs A and E shall only be displayed when the MTM vehicle is placed on a live traffic lane on a motorway or all-purpose dual carriageway (including their one way slip roads) and indicates that vehicles must only pass to the left of the MTM vehicle situated in the carriageway; and
10. directs that the authorised signs B and F shall only be displayed when the MTM vehicle is placed on a live traffic lane on a motorway or all-purpose dual carriageway (including their one way slip roads) and indicates that vehicles must only pass to the right of the MTM vehicle situated in the carriageway; and
11. directs that the authorised signs C and G shall only be displayed when the MTM vehicle is placed on the hard shoulder (or any other part of the carriageway which is not a live traffic lane) on a motorway or all-purpose dual carriageway road (including their one way slip roads); and



12. directs that the authorised signs D and H shall only be displayed when the MTM vehicle is placed on a live traffic lane on a single carriageway road; and
13. directs that the Light Emitting Arrow on the authorised signs A, B, E and F shall pulse at a rate of 30 to 50 flashes per minute and that the on-period shall be twice the length of the off-period; and
14. directs that the two light roundels at the top of the of the authorised signs A, B, C, E, F and G shall flash simultaneously. When used with the authorised signs A, B, E and F, the two light roundels shall only flash during the off-period of the Light Emitting Arrow. When used with authorised signs C and G, the two light roundels shall flash at a rate of between 30 to 50 flashes per minute and that the on-period shall be twice the length of the off-period; and
15. directs that the four light roundels on the authorised signs D and H shall flash in vertical pairs and that each roundel shall show an intermittent light at a rate of flashing of not less than 60 nor more than 90 flashes per minute, and in such a manner that the lights of one vertical pair are always shown (on) when the lights of the other vertical pair are not shown (off); and
16. directs that the authorised signs A, B, E and F may be used in place of signs conforming to Diagram 610 in Schedule 13, Part 6, Item 11 or Diagram 7403 in Schedule 13, Part 6, Item 10 to the Traffic Signs Regulations and General Directions 2016 (Part 1 of S.I. 2016/362, “the 2016 Regulations”) where the permanent maximum speed limit is 40 mph or lower; and
17. directs that the authorised signs A, B, E and F may be used in place of signs conforming to Diagram 610 in Schedule 13, Part 6, Item 11 of the 2016 Regulations where the permanent maximum speed limit is over 40 mph; and
18. directs that the authorised signs C, D, G and H may be displayed on a MTM vehicle where the speed limit for the road the vehicle is placed on is the National Speed Limit, or lower; and



19. directs that the authorised signs A to H shall only be used on MTM vehicles which are being used for works, mobile lane closures or mobile carriageway closures as indicated in Chapter 8 of the Traffic Signs Manual (TSM) or for emergency traffic management; and
20. directs that the authorised signs A to H shall be so installed so that the highest part of the sign assembly, including any lights or beacons, when the lightest gross in-service vehicle weight applies, is no greater than 4.98 metres above ground level; and
21. directs that the authorised signs A to H shall only be placed on the road, by personnel trained to do so in accordance with the relevant Sector Scheme and in accordance with any specific equipment, operational, maintenance and monitoring requirements specified by the manufacturer; and
22. directs that when not displaying any authorised sign, the unit shall be off and display a blank grey face; and
23. directs, without prejudice to any statutory provisions to the like effect, that it is a condition of this authorisation that the placing of a MTM vehicle displaying the authorised signs A to H on a road shall continue to have effect only until such day as may be appointed by one month's notice given by the Secretary of State in writing to the traffic authority for the removal or alteration of the authorised signs A to H and on that day the said authorisation shall, without prejudice to the giving of any further authorisation or direction, cease to have effect.

The provisions of Regulations 5 and 7 of the 2016 Regulations shall apply to the authorised signs A to H in the same manner as they apply to the sign shown in Diagram 7403 in Schedule 13, Part 6, Item 10 to those Regulations.



The provisions of Schedule 9, Part 7, Item 9 paragraph 5(e) of the 2016 Regulations shall apply to the authorised signs A, B, E and F in the same manner as they apply to the sign shown in Diagram 7403 in Schedule 13, Part 6, Item 10 of those Regulations.

The provisions of Schedule 13, Part 7, Item 1 of the 2016 Regulations shall apply to the authorised signs A, B, E and F in the same manner as they apply to the sign shown in Diagram 7403 in Schedule 13, Part 6, Item 10 of those Regulations.

The provisions of Schedule 13, Part 12, Item 6(3) of the 2016 Regulations shall apply to the authorised signs A to H.

Dated *05 November 2021*

Signed by authority of the Secretary of State

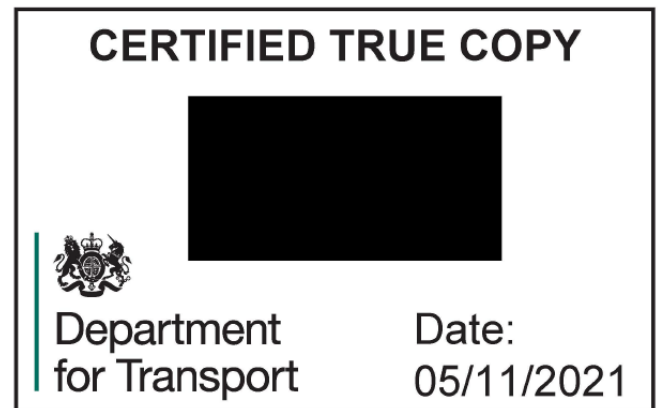
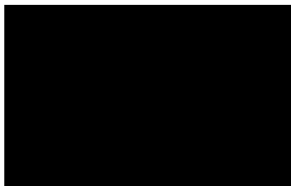

.....
A Delegated Official of the Department for Transport

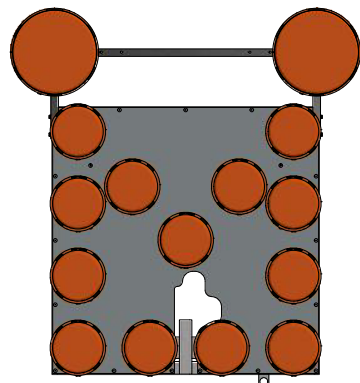

LP13 off

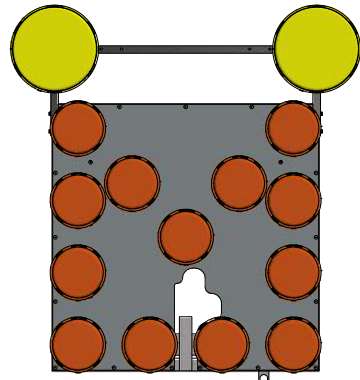

"Aspect C"

two fold 340mm lamps flashing
(60 to 90 Flashes per minute)

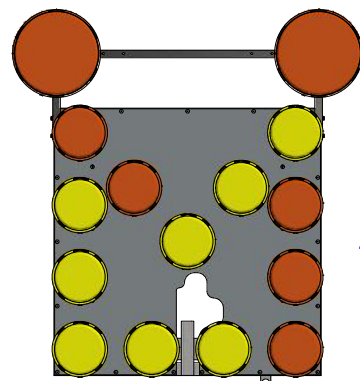

"Aspect A"

Light arrow left with alternative two fold 340mm lamps
(30 to 50 Flashes per minute)

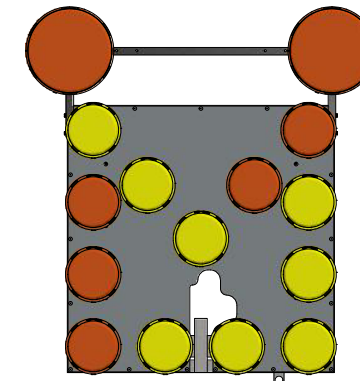

"Aspect B"

Light arrow right with alternative two fold 340mm lamps
(30 to 50 Flashes per minute)

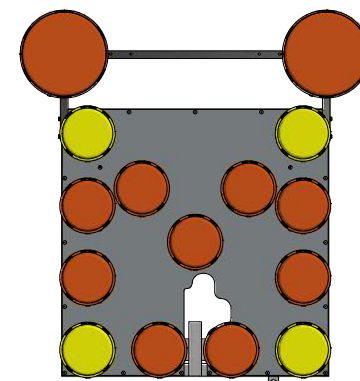

"Aspect D"

four fold alternate flashing and two fold 340mm lamps flashing
(60 to 90 Flashes per minute)

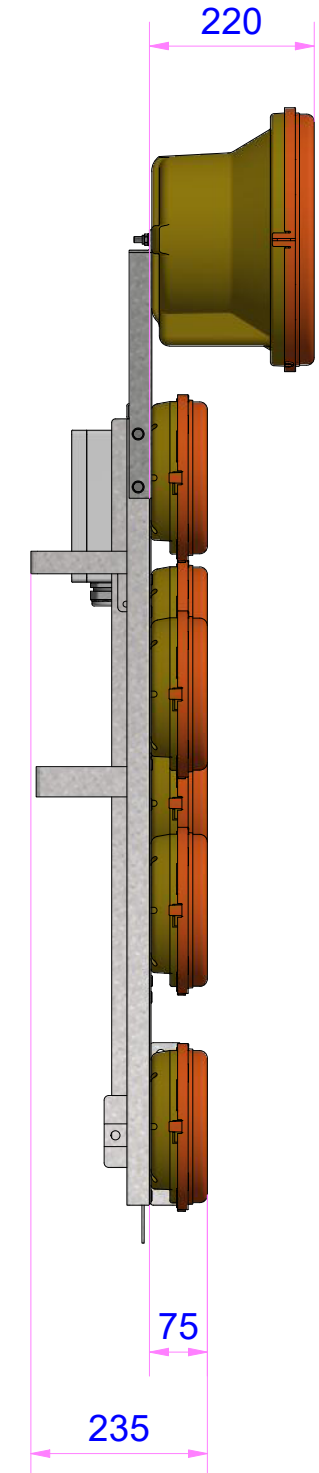
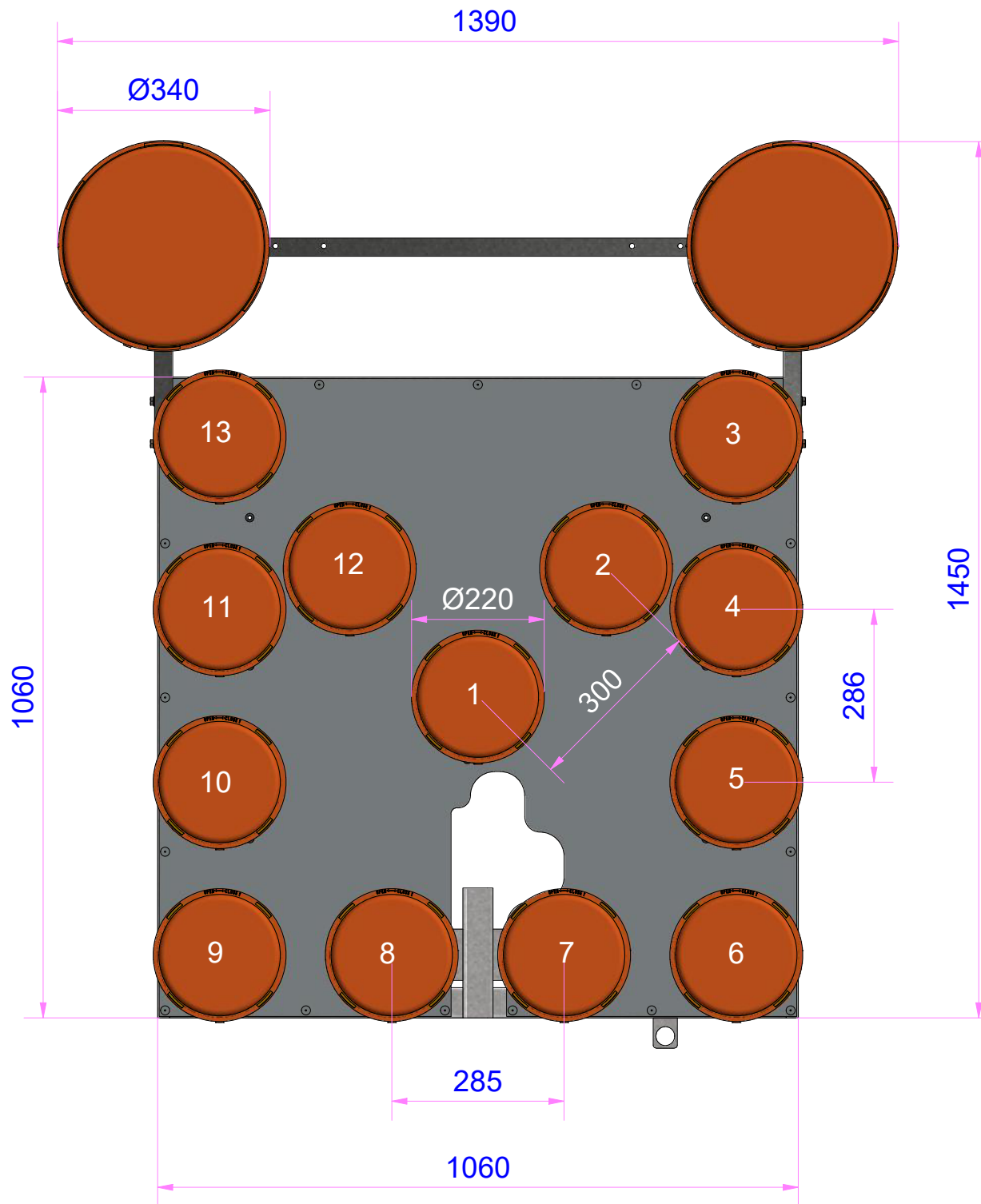

A vertical or horizontal lifting light board options are also available



Department for Transport
 Date: 27 October 2021
 Number: GT50/198/0087-1

no.	change	date	name	© Adolf Nissen Elektrobau 2004 - All rights reserved. This drawing may not be made available to a third party nor be used improper by the recipient or a third party.		
d				date	name	material
c				drawn	25.09.2020	K. Hansen
b				verified	15.02.2021	I. Sharif
a		15.02.21	K.H.	Dimensions Mini Light Arrow LP13 with two fold 340mm lamps		
replacement for/by						
material no.			A/06	drawing no.		
				scale		

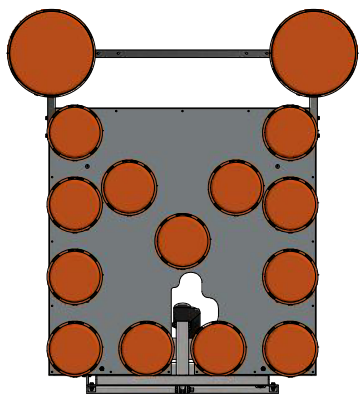
nissen
 ROAD SAFETY SOLUTIONS
 Elektrobau D-25832 Tönning
 Tel. (+494861) 612-0 Fax (+494861) 612-144
 drawing no. 201007-1a
 scale /

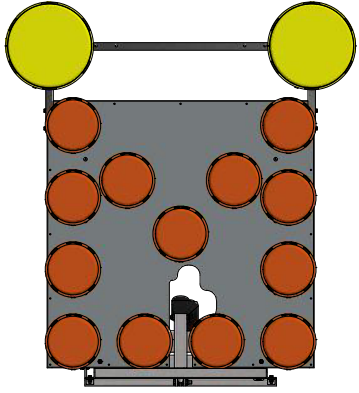

LP13 off



"Aspect C"

two fold 340mm lamps flashing
(60 to 90 Flashes per minute)

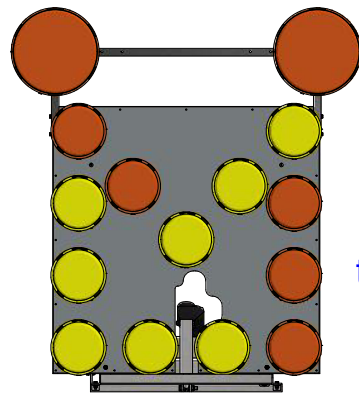

"Aspect A"

Light arrow left with alternative two fold 340mm lamps
(30 to 50 Flashes per minute)

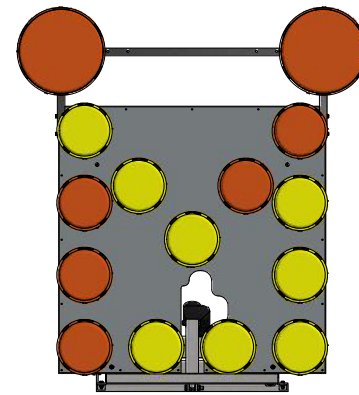

"Aspect B"

Light arrow right with alternative two fold 340mm lamps
(30 to 50 Flashes per minute)

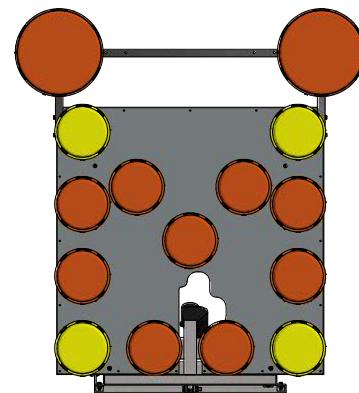

"Aspect D"

four fold alternate flashing and two fold 340mm lamps flashing
(60 to 90 Flashes per minute)

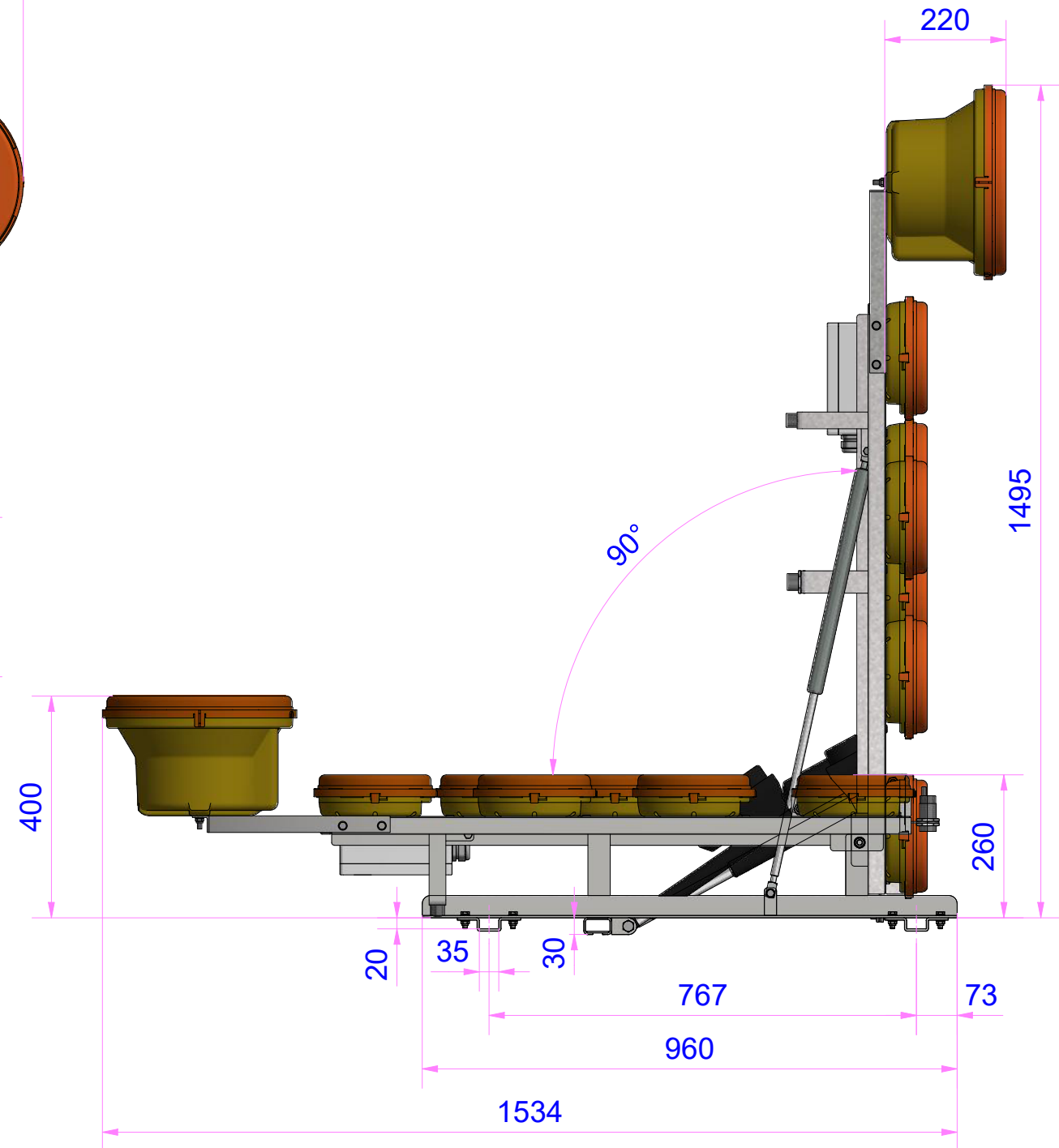
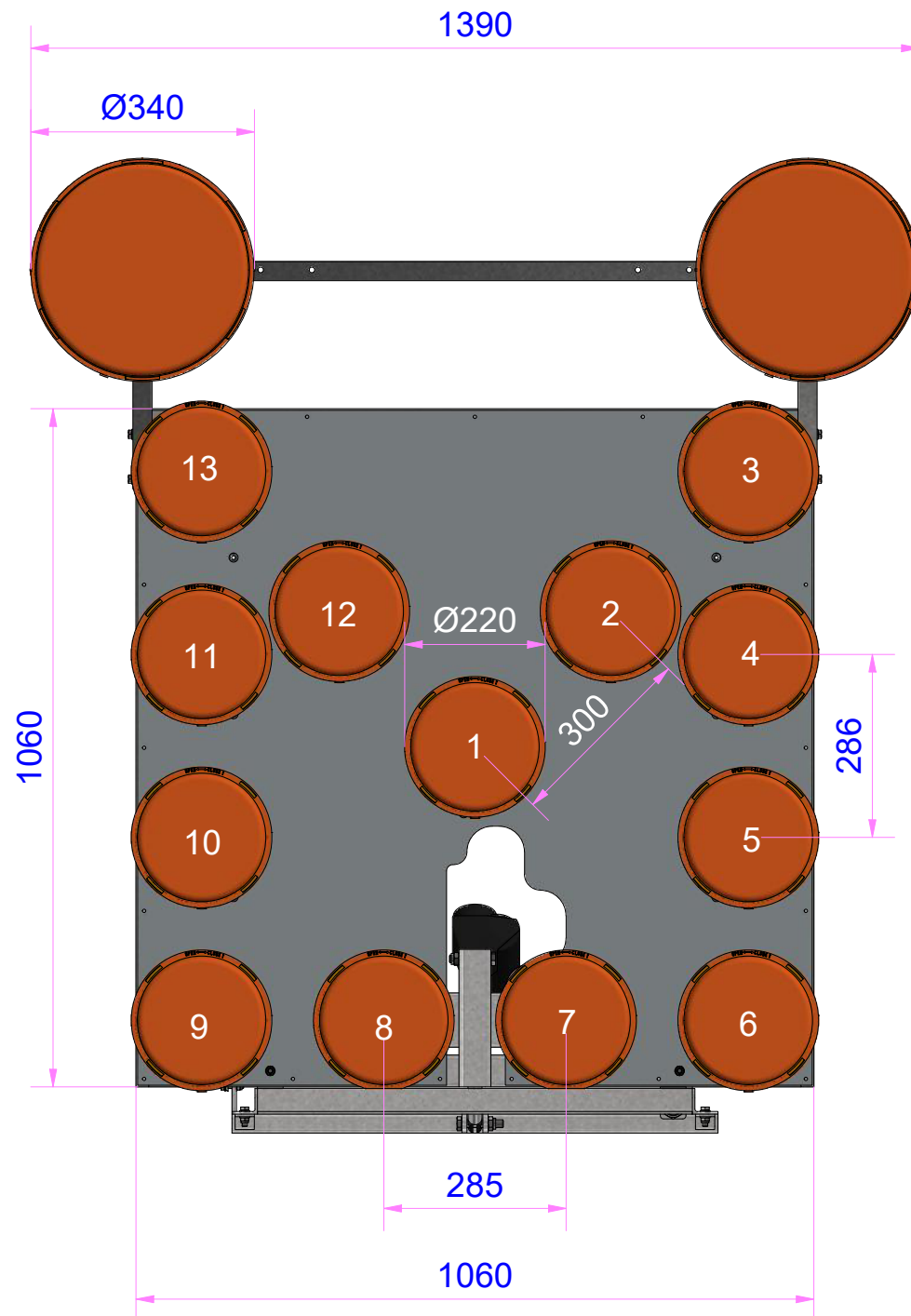

 Department
 for Transport

Date: 27 October 2021

Number: GT50/198/0087-2

no.	change	date	name	© Adolf Nissen Elektrobau 2004 - All rights reserved. This drawing may not be made available to a third party nor be used improper by the recipient or a third party.			
d				date	name	material	
c				drawn	30.09.2020	K. Hansen	
b				verified	15.02.2021	I. Sharif	
a		15.02.21	K.H.	Dimensions Mini Light Arrow LP13 with two fold 340mm lamps (raise/lower)			
replacement for/by							
material no.			A/06	drawing no.		scale	
						201007-2a	/

 ROAD SAFETY SOLUTIONS
 Elektrobau D-25832 Tönning
 Tel. (+494861) 612-0 Fax (+494861) 612-144