



Department  
for Transport

## Road Traffic Regulation Act 1984 Sections 64 and 65

### Authorisation of traffic signs and special directions

#### Accessible transcript

Secretary of State for Transport's traffic authorisation of traffic signs for the purpose of informing public rights of way users of the crossing prerequisites in the vicinity of the Lodge Lane Level Crossing in Farington, Lancashire, for which the traffic authority Lancashire County Council permits the placing of signs by Network Rail.

The following pages contain a copy of the text from the Secretary of State for Transport's traffic authorisation regarding the above traffic signs.

A scanned copy of the signed authorisation and supporting documents from the application are appended to this letter. The supporting material is submitted to the Department for Transport by a third party. You should refer to the party involved for accessible copies of the supporting material.



**ROAD TRAFFIC REGULATION ACT – SECTIONS 64 AND 65  
AUTHORISATION OF TRAFFIC SIGNS AND SPECIAL DIRECTIONS**

The Secretary of State for Transport, in exercise of his powers under Sections 64 and 65 of the Road Traffic Regulation Act 1984, and of all other powers enabling him in that behalf for the purpose of informing public rights of way users of the crossing prerequisites in the vicinity of the Lodge Lane Level Crossing in Farington, Lancashire, for which the traffic authority Lancashire County Council permits the placing of signs by Network Rail, hereby:-

1. authorises the erection at or within 5 metres of the sites marked schematically on the attached plan numbered GT50/064/0037-1 of a traffic sign (hereinafter referred to as “the authorised sign A”) conforming as to size, colour and character with that shown in the attached drawing numbered GT50/064/0037-2; and
2. authorises the erection at or within 5 metres of the sites marked schematically on the attached plan numbered GT50/064/0037-1 of a traffic sign (hereinafter referred to as “the authorised sign B”) conforming as to size, colour and character with that shown in the attached drawing numbered GT50/064/0037-3; and
3. authorises the erection at or within 5 metres of the sites marked schematically on the attached plan numbered GT50/064/0037-1 of a traffic sign (hereinafter referred to as “the authorised sign C”) conforming as to size, colour and character with that shown in the attached drawing numbered GT50/064/0037-4; and
4. authorises the erection at or within 5 metres of the sites marked schematically on the attached plan numbered GT50/064/0037-1 of a traffic sign (hereinafter referred to as “the authorised sign D”) conforming as to size, colour and character with that shown in the attached drawing numbered GT50/064/0037-5; and
5. authorises the erection at or within 5 metres of the sites marked schematically on the attached plan numbered GT50/064/0037-1 of a traffic sign (hereinafter referred to as “the authorised sign E”) conforming as to size, colour and character with that shown in the attached drawing numbered GT50/064/0037-6; and



6. directs, without prejudice to any statutory provision to the like effect, that it is a condition of this authorisation that the erection of the authorised signs A to E at or near the said sites shall continue to have effect only until such day as may be appointed by one month's notice given by the Secretary of State in writing to the traffic authority for the removal or alteration of the authorised signs A to E and on that day the said authorisation shall, without prejudice to the giving of any further authorisation or direction, cease to have effect.

The provisions of Regulations 7 and 11 of the Traffic Signs Regulations 2016 (Part 1 of S.I. 2016/362, "the 2016 Regulations") shall apply to the authorised sign A in the same manner as they apply to the sign to diagram 770 shown in Schedule 2, Part 2, Item 51 of those Regulations.

The provisions of Regulation 11 of the 2016 Regulations shall apply to the authorised signs B to E in the same manner as they apply to the signs shown in those Regulations.

Dated *13 July 2022*

Signed by authority of the Secretary of State

.....

A Delegated Official of the Department for Transport



Department  
for Transport

**SCANNED  
AUTHORISATION  
AND SUPPORTING  
DOCUMENTS  
FOLLOW**



**ROAD TRAFFIC REGULATION ACT – SECTIONS 64 AND 65  
AUTHORISATION OF TRAFFIC SIGNS AND SPECIAL DIRECTIONS**

The Secretary of State for Transport, in exercise of his powers under Sections 64 and 65 of the Road Traffic Regulation Act 1984, and of all other powers enabling him in that behalf for the purpose of informing public rights of way users of the crossing prerequisites in the vicinity of the Lodge Lane Level Crossing in Farington, Lancashire, for which the traffic authority Lancashire County Council permits the placing of signs by Network Rail, hereby:-

1. authorises the erection at or within 5 metres of the sites marked schematically on the attached plan numbered GT50/064/0037-1 of a traffic sign (hereinafter referred to as “the authorised sign A”) conforming as to size, colour and character with that shown in the attached drawing numbered GT50/064/0037-2; and
2. authorises the erection at or within 5 metres of the sites marked schematically on the attached plan numbered GT50/064/0037-1 of a traffic sign (hereinafter referred to as “the authorised sign B”) conforming as to size, colour and character with that shown in the attached drawing numbered GT50/064/0037-3; and
3. authorises the erection at or within 5 metres of the sites marked schematically on the attached plan numbered GT50/064/0037-1 of a traffic sign (hereinafter referred to as “the authorised sign C”) conforming as to size, colour and character with that shown in the attached drawing numbered GT50/064/0037-4; and
4. authorises the erection at or within 5 metres of the sites marked schematically on the attached plan numbered GT50/064/0037-1 of a traffic sign (hereinafter referred to as “the authorised sign D”) conforming as to size, colour and character with that shown in the attached drawing numbered GT50/064/0037-5; and
5. authorises the erection at or within 5 metres of the sites marked schematically on the attached plan numbered GT50/064/0037-1 of a traffic sign (hereinafter referred to as “the authorised sign E”) conforming as to size, colour and character with that shown in the attached drawing numbered GT50/064/0037-6; and



6. directs, without prejudice to any statutory provision to the like effect, that it is a condition of this authorisation that the erection of the authorised signs A to E at or near the said sites shall continue to have effect only until such day as may be appointed by one month's notice given by the Secretary of State in writing to the traffic authority for the removal or alteration of the authorised signs A to E and on that day the said authorisation shall, without prejudice to the giving of any further authorisation or direction, cease to have effect.

The provisions of Regulations 7 and 11 of the Traffic Signs Regulations 2016 (Part 1 of S.I. 2016/362, "the 2016 Regulations") shall apply to the authorised sign A in the same manner as they apply to the sign to diagram 770 shown in Schedule 2, Part 2, Item 51 of those Regulations.

The provisions of Regulation 11 of the 2016 Regulations shall apply to the authorised signs B to E in the same manner as they apply to the signs shown in those Regulations.

Dated *13 July 2022*

Signed by authority of the Secretary of State

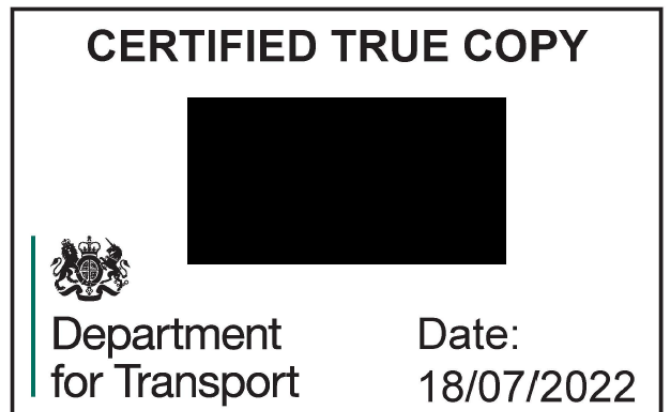
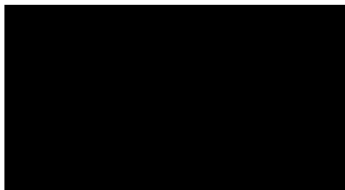

.....  
A Delegated Official of the Department for Transport



# Site Location Map

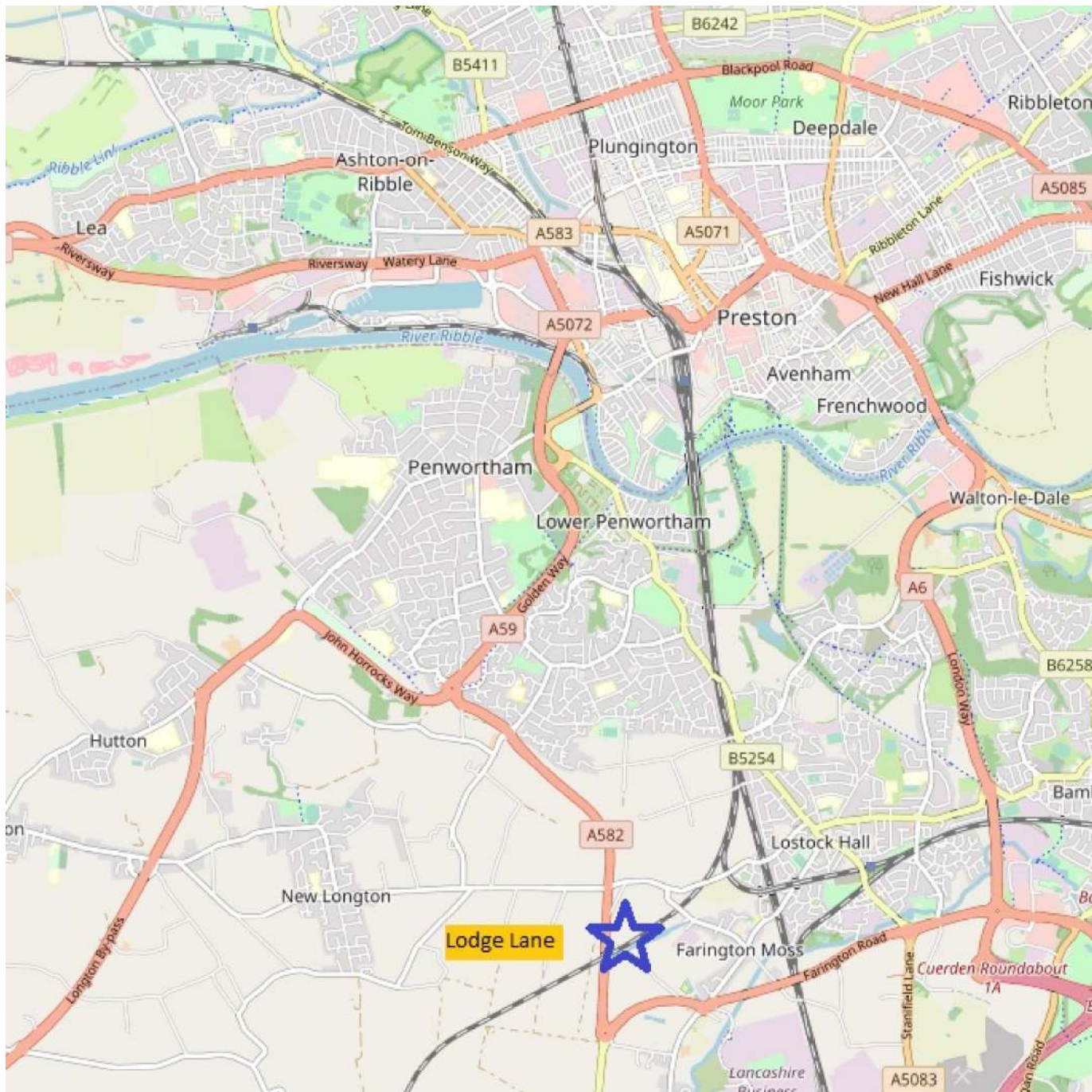

Department  
for Transport

Date: 11 July 2022

Number: GT50/064/0037-1

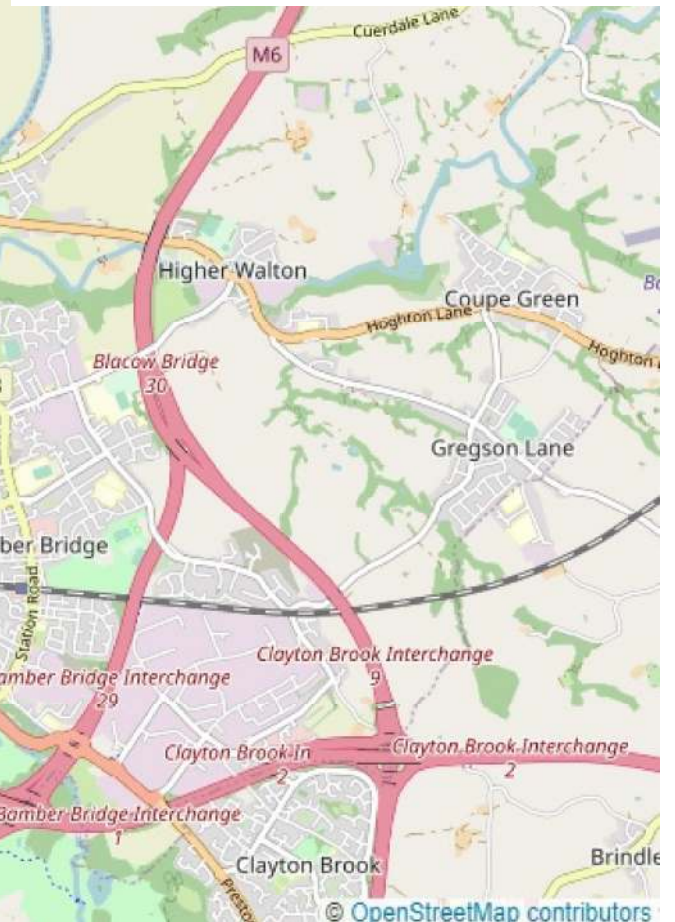

LODGE LANE - SITE PLAN

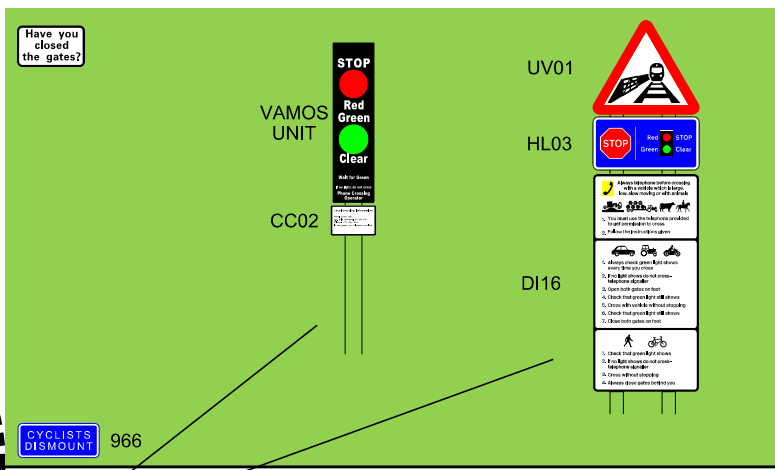
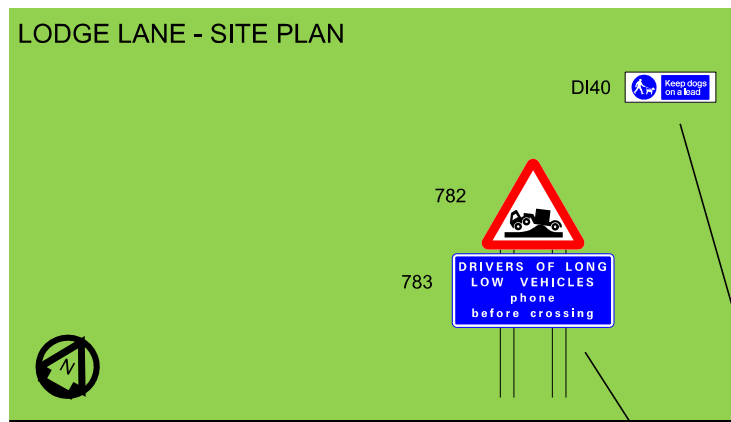

Sign mounted on two posts and angled optimally for user

Sign mounted on two posts and angled optimally for user

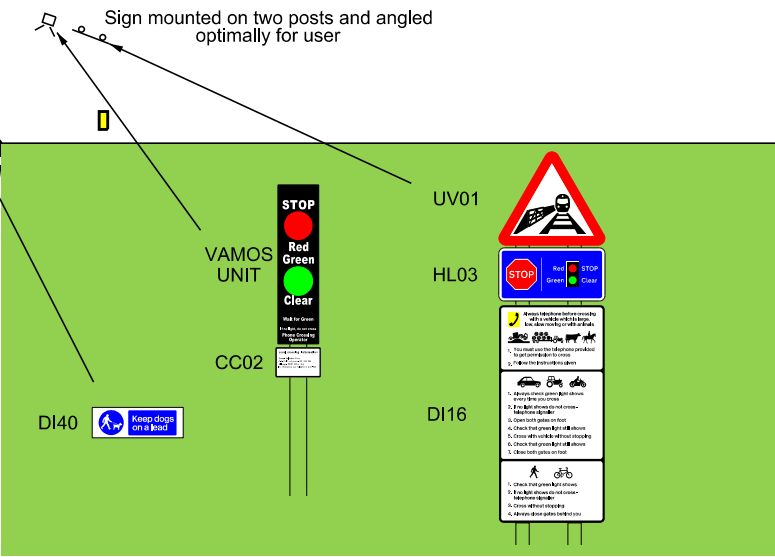
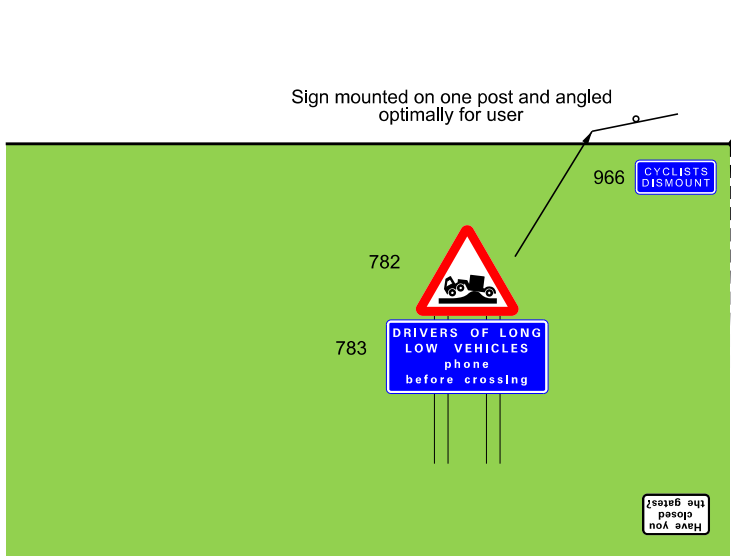

Sign mounted on one post and angled optimally for user

Sign mounted on two posts and angled optimally for user



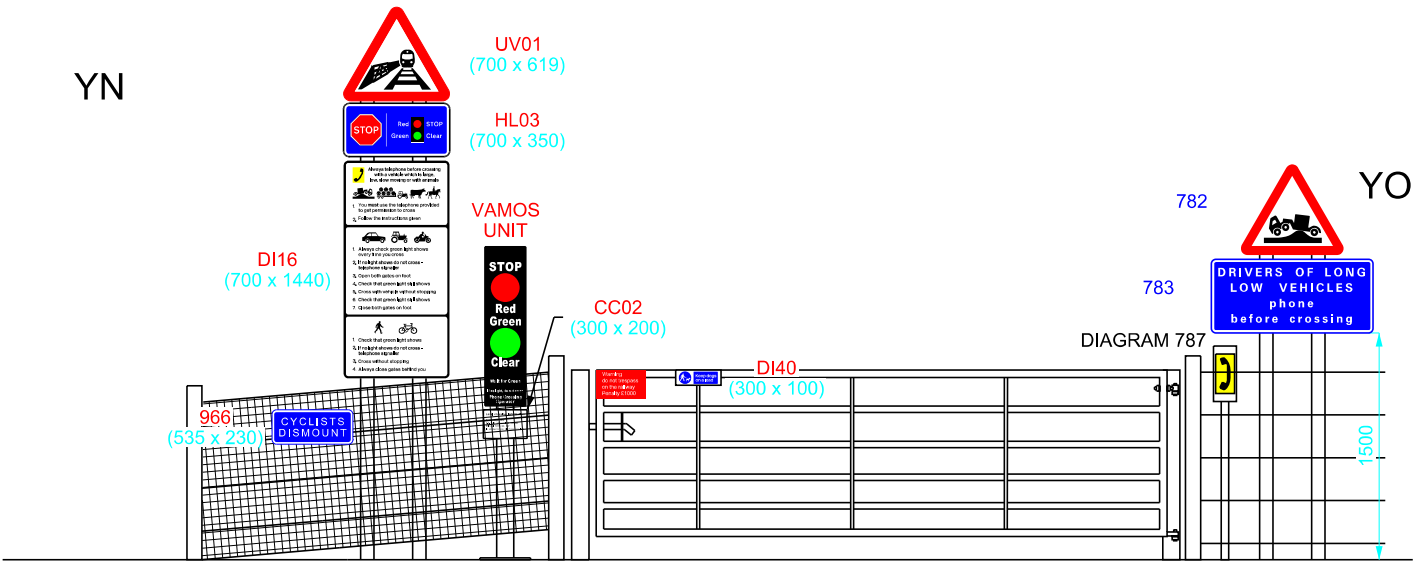

UP ELEVATION

CARRIAGEWAY LEVEL DOES NOT REFLECT ACTUAL GROUND PROFILE

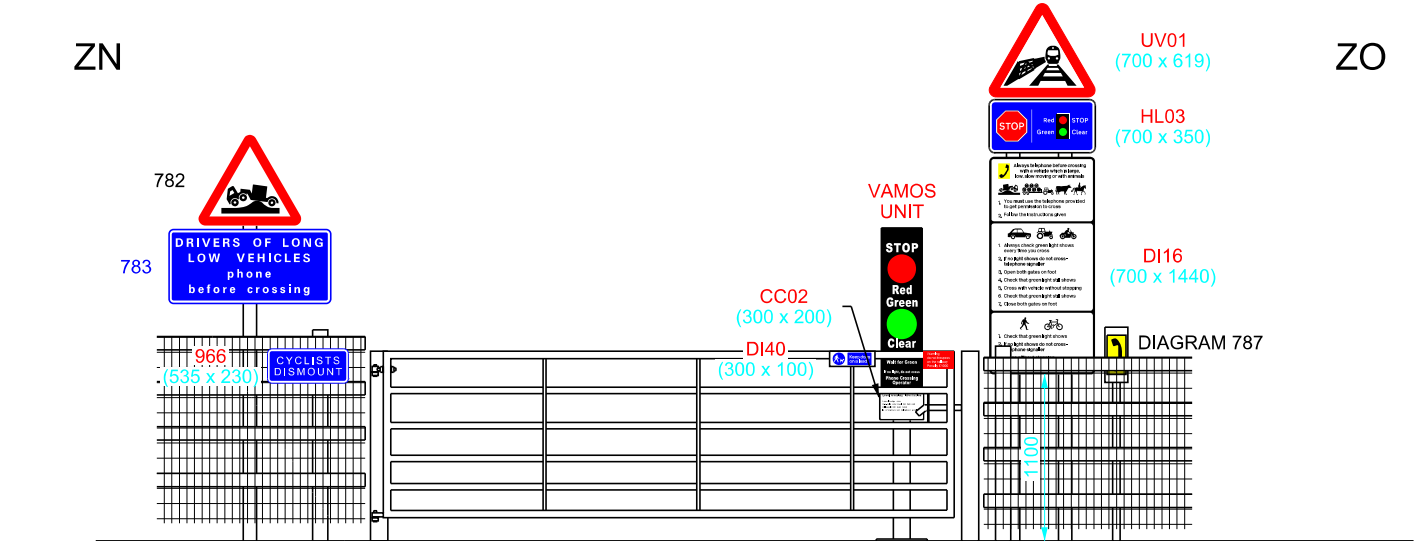
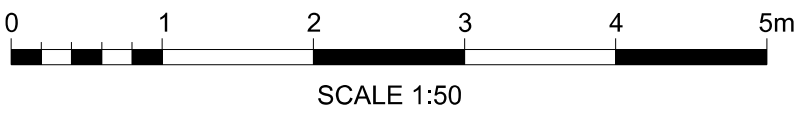

DOWN ELEVATION

CARRIAGEWAY LEVEL DOES NOT REFLECT ACTUAL GROUND PROFILE



VAMOS UNIT

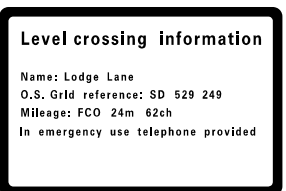

CC02 (A)

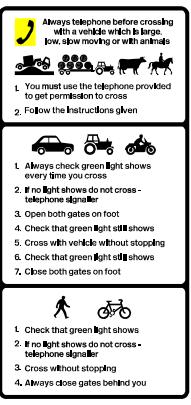

DI16



UV01

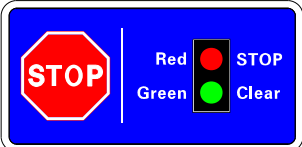

HL03



DI40

SIGNAGE



Department  
for Transport

Date: 11 July 2022

Number: GT50/064/0037-2

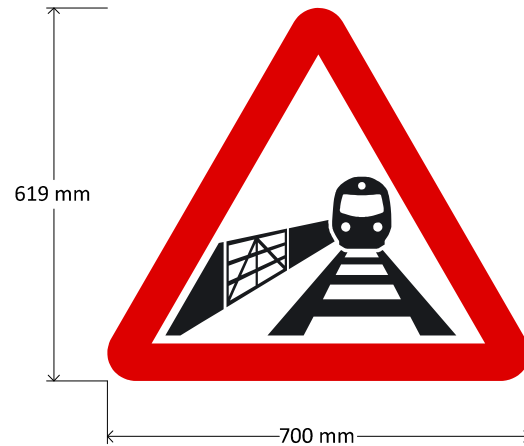

RBLI

*Improving lives every day*

Royal British Legion Industries,  
Hall Road, Aylesford, Kent,  
ME20 7NL  
www.rbli.co.uk

Email: sales.office@rbli.co.uk  
Tel: 01622 795900

www.britainsbravestmanufacturing.org.uk

Client: **Network Rail**  
**(Crossing Samples)**

Drawing No. UV01	Rev. No. 2
Date	24/01/2020
Size	600, 700, 800mm
Substrate	ACM
Colours	Various
Material Type	RA2
Font	N/A
Letter Height	N/A
xht (DoT only)	N/A
Border	To suit
Rads	To suit
Fixings	TBC

Additional Information:

SUPPORTING OUR FORCES  
— MADE BY —  
**BRITAIN'S BRAVEST**  
MANUFACTURING CO.  
SINCE 1919

Please check all details are correct before approving this drawing. Once approved, your sign will be made to this detail.

Proof Approved:

Signed.....

Date.....

PLEASE NOTE: Colours on this drawing are for representation only. If you require specific colour references, please specify when placing an order.



RBLI

*Improving lives every day*

Royal British Legion Industries,  
Hall Road, Aylesford, Kent,  
ME20 7NL  
www.rbli.co.uk

Email: sales.office@rbli.co.uk  
Tel: 01622 795900

www.britainsbravestmanufacturing.org.uk

Client: **Network Rail**  
**(Crossing Samples)**

Drawing No. DI16 | Rev. No. 3

Date | 10/08/2021

Size | as shown

Substrate | ACM

Colours | Various

Material Type | RA2

Font | Transport

Letter Height | 22, 23mm

xht (DoT only) | N/A

Border | 15mm

Rads | 31mm (62.5/2)

Fixings | TBC

Additional Information:

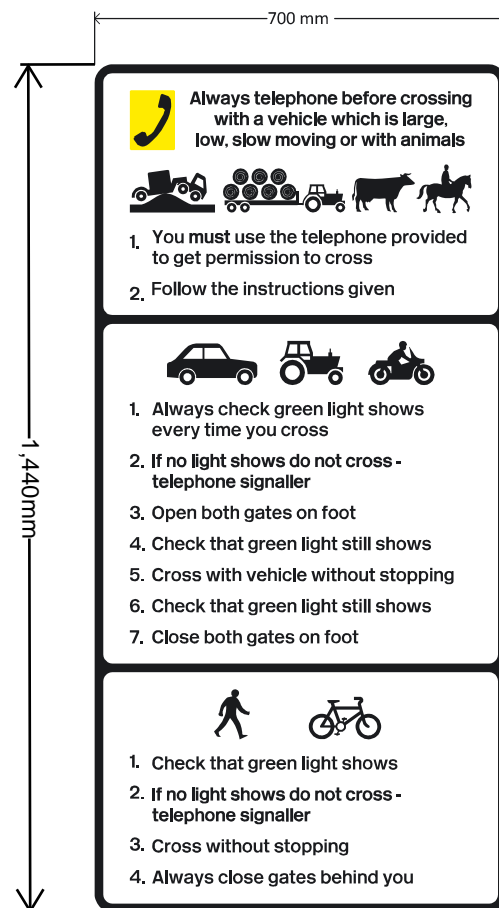

Department  
for Transport

Date: 11 July 2022

Number: GT50/064/0037-3

Please check all details are correct before approving this drawing. Once approved, your sign will be made to this detail.

Proof Approved:

Signed.....

Date.....

PLEASE NOTE: Colours on this drawing are for representation only. If you require specific colour references, please specify when placing an order.

OFFICIAL

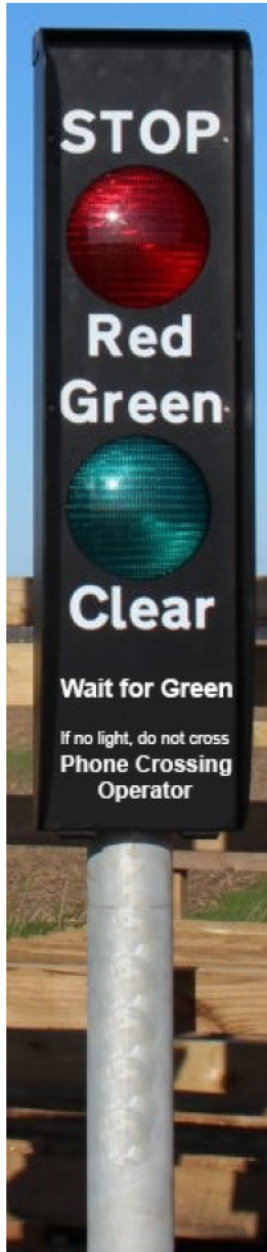

Proprietary VaMOS head



Department  
for Transport

Date: 11 July 2022

Number: GT50/064/0037-4

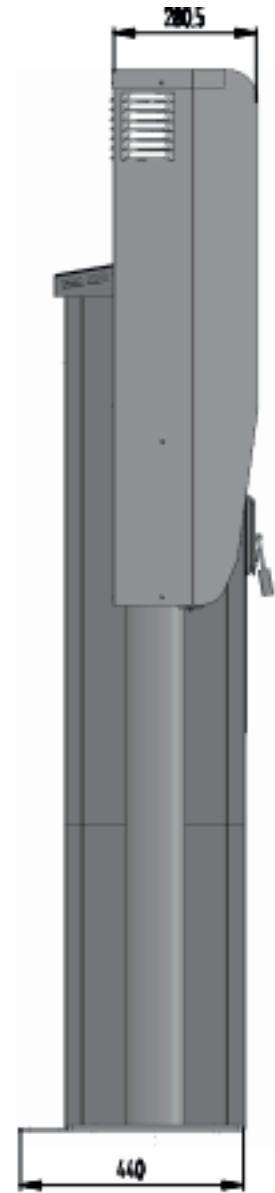
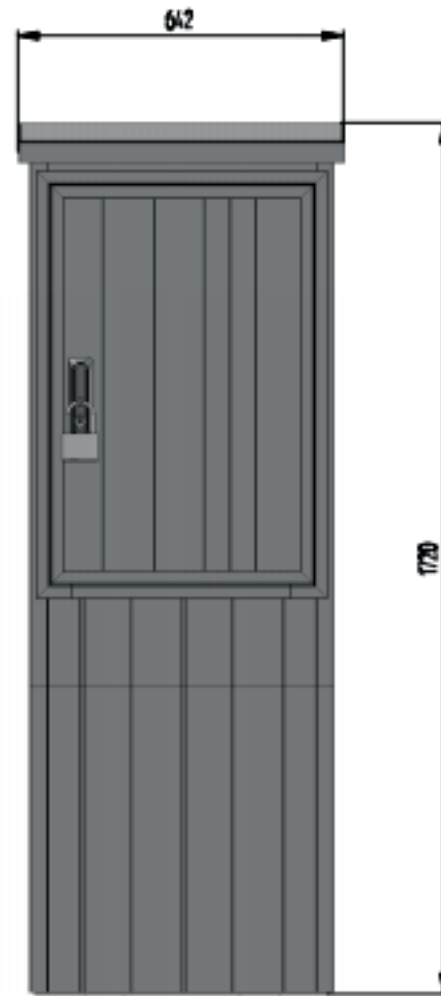
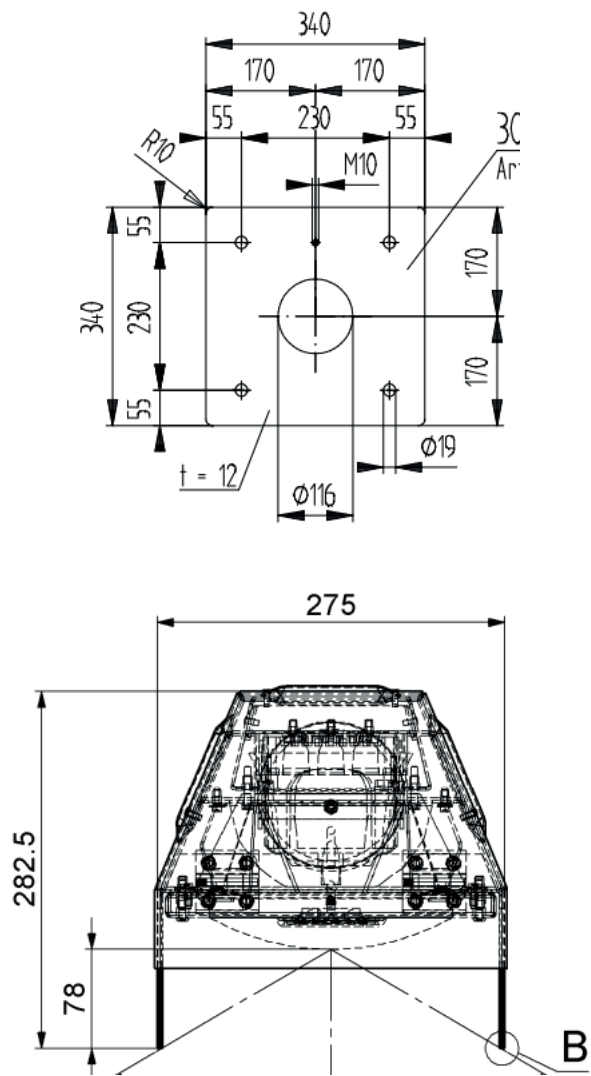





RBLI

*Improving lives every day*

Royal British Legion Industries,  
Hall Road, Aylesford, Kent,  
ME20 7NL  
www.rbli.co.uk

Email: sales.office@rbli.co.uk  
Tel: 01622 795900

www.britainsbravestmanufacturing.org.uk

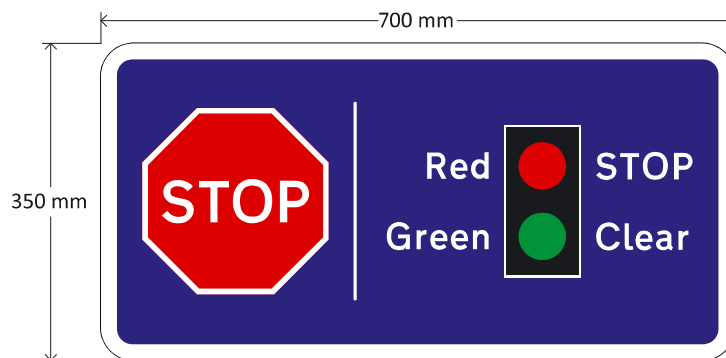

Client: **Network Rail**  
**(Crossing Samples)**

Drawing No. HL03 Rev. No. 2

Date 24/01/2020

Size as shown

Substrate ACM

Colours Various

Material Type RA2

Font Transport

Letter Height 33mm

xht (DoT only) N/A

Border 20mm

Rads 38mm (50/3)

Fixings TBC

Additional Information:



Department  
for Transport

Date: 11 July 2022

Number: GT50/064/0037-5



Please check all details are correct before approving this drawing. Once approved, your sign will be made to this detail.

Proof Approved:

Signed.....

Date.....

PLEASE NOTE: Colours on this drawing are for representation only. If you require specific colour references, please specify when placing an order.



**RBLI**

*Improving lives every day*

Royal British Legion Industries,  
Hall Road, Aylesford, Kent,  
ME20 7NL  
www.rbli.co.uk

Email: sales.office@rbli.co.uk  
Tel: 01622 795900

www.britainsbravestmanufacturing.org.uk

Client: **Network Rail**  
**(Crossing Samples)**

Drawing No. DI40 | Rev. No. 2

Date | 23/08/2021

Size | as shown

Substrate | ACM

Colours | Various

Material Type | RA2

Font | Transport

Letter Height | 23, 26mm

xht (DoT only) | N/A

Border | 15mm

Rads | 31mm (62.5/2)

Fixings | TBC

Additional Information:



Department  
for Transport

Date: 11 July 2022

Number: GT50/064/0037-6

Please check all details are correct before approving this drawing. Once approved, your sign will be made to this detail.

Proof Approved:

Signed.....

Date.....

PLEASE NOTE: Colours on this drawing are for representation only. If you require specific colour references, please specify when placing an order.