



Department
for Transport

Road Traffic Regulation Act 1984 Sections 64 and 65

Authorisation of traffic signs and special directions

Accessible transcript

Secretary of State for Transport's traffic authorisation of traffic signs

The following pages contain a copy of the text from the Secretary of State for Transport's traffic authorisation regarding the above traffic signs.

A scanned copy of the signed authorisation and supporting documents from the application are appended to this letter. The supporting material is submitted to the Department for Transport by a third party. You should refer to the party involved for accessible copies of the supporting material.



ROAD TRAFFIC REGULATION ACT 1984 – SECTIONS 64 AND 65
AUTHORISATION OF TRAFFIC SIGNS AND SPECIAL DIRECTIONS

The Secretary of State for Transport, in exercise of his powers under Sections 64 and 65 of the Road Traffic Regulation Act 1984, and of all other powers enabling him in that behalf, for the purpose of informing road users of access restrictions at appropriate sites on roads for which London Borough of Lambeth is the traffic authority, hereby:-

1. authorises the erection at the said sites of a traffic sign (hereinafter referred to as “the authorised sign”) conforming as to size, colour and character with that shown on the attached drawing numbered GT50/088/0019-1; and
2. directs that the authorised sign shall be used with an indicator of the same size, colour and type as the traffic light signal shown in diagram 3000 in Schedule 14, Part 2, Item 1 of the Traffic Signs Regulations 2016 (Part 1 of S.I. 2016/362, “the 2016 Regulations”); and
3. directs that when illuminated, the red signal in the indicator denotes the period during which an automatic bollard is in the closed position and that vehicular traffic must not proceed; and
4. directs that when illuminated, the green signal in the indicator denotes the period during which an automatic bollard is in the open position and that vehicular traffic may proceed; and
5. directs that it is a condition of this authorisation that the authorised sign shall be erected only to indicate the effect of a corresponding Traffic Regulation Order; and



6. directs, without prejudice to any statutory provision to the like effect, that it is a condition of this authorisation that the erection of the authorised sign at or near the said sites shall continue to have effect only until such day as may be appointed by one month's notice given by the Secretary of State in writing to the traffic authority for the removal or alteration of the authorised sign and on that day the said authorisation shall, without prejudice to the giving of any further authorisation or direction, cease to have effect.

The provisions of Regulation 7 and Schedule 14, Part 1, Paragraph 28(1) and 28(3) of the 2016 Regulations shall apply to the apparatus in the same manner as they apply to the traffic light signal shown in diagram 3000 in Schedule 14, Part 2, Item 1 of those Regulations.

Dated *02 May 2024*

Signed by authority of the Secretary of State

.....

A Delegated Official of the Department for Transport



Department
for Transport

**SCANNED
AUTHORISATION
AND SUPPORTING
DOCUMENTS
FOLLOW**



ROAD TRAFFIC REGULATION ACT 1984 – SECTIONS 64 AND 65

AUTHORISATION OF TRAFFIC SIGNS AND SPECIAL DIRECTIONS

The Secretary of State for Transport, in exercise of his powers under Sections 64 and 65 of the Road Traffic Regulation Act 1984, and of all other powers enabling him in that behalf, for the purpose of informing road users of access restrictions at appropriate sites on roads for which London Borough of Lambeth is the traffic authority, hereby:-

1. authorises the erection at the said sites of a traffic sign (hereinafter referred to as “the authorised sign”) conforming as to size, colour and character with that shown on the attached drawing numbered GT50/088/0019-1; and
2. directs that the authorised sign shall be used with an indicator of the same size, colour and type as the traffic light signal shown in diagram 3000 in Schedule 14, Part 2, Item 1 of the Traffic Signs Regulations 2016 (Part 1 of S.I. 2016/362, “the 2016 Regulations”); and
3. directs that when illuminated, the red signal in the indicator denotes the period during which an automatic bollard is in the closed position and that vehicular traffic must not proceed; and
4. directs that when illuminated, the green signal in the indicator denotes the period during which an automatic bollard is in the open position and that vehicular traffic may proceed; and
5. directs that it is a condition of this authorisation that the authorised sign shall be erected only to indicate the effect of a corresponding Traffic Regulation Order; and



Department for Transport

GT50/088/0019

6. directs, without prejudice to any statutory provision to the like effect, that it is a condition of this authorisation that the erection of the authorised sign at or near the said sites shall continue to have effect only until such day as may be appointed by one month's notice given by the Secretary of State in writing to the traffic authority for the removal or alteration of the authorised sign and on that day the said authorisation shall, without prejudice to the giving of any further authorisation or direction, cease to have effect.

The provisions of Regulation 7 and Schedule 14, Part 1, Paragraph 28(1) and 28(3) of the 2016 Regulations shall apply to the apparatus in the same manner as they apply to the traffic light signal shown in diagram 3000 in Schedule 14, Part 2, Item 1 of those Regulations.

Dated *02 May 2024*

Signed by authority of the Secretary of State

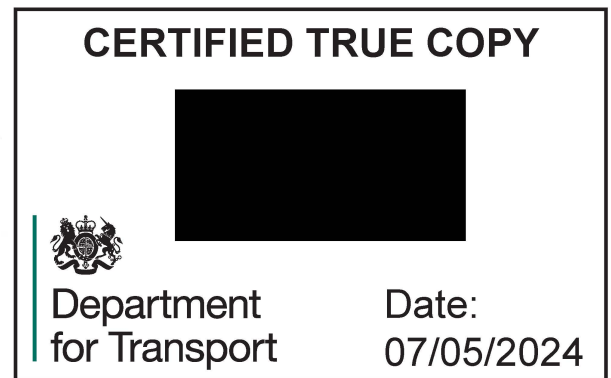

A Delegated Official of the Department for Transport

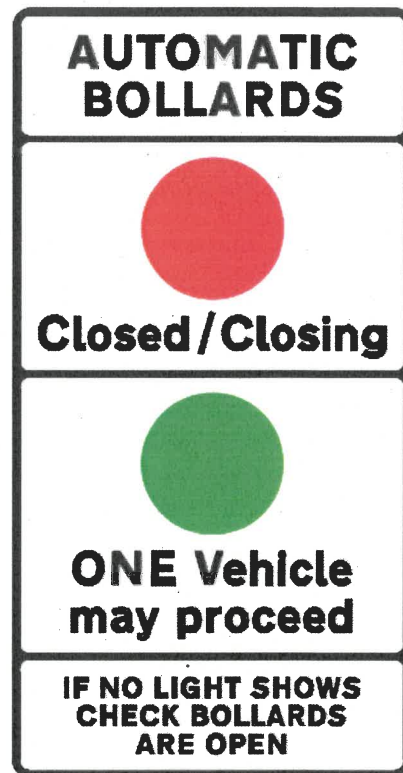
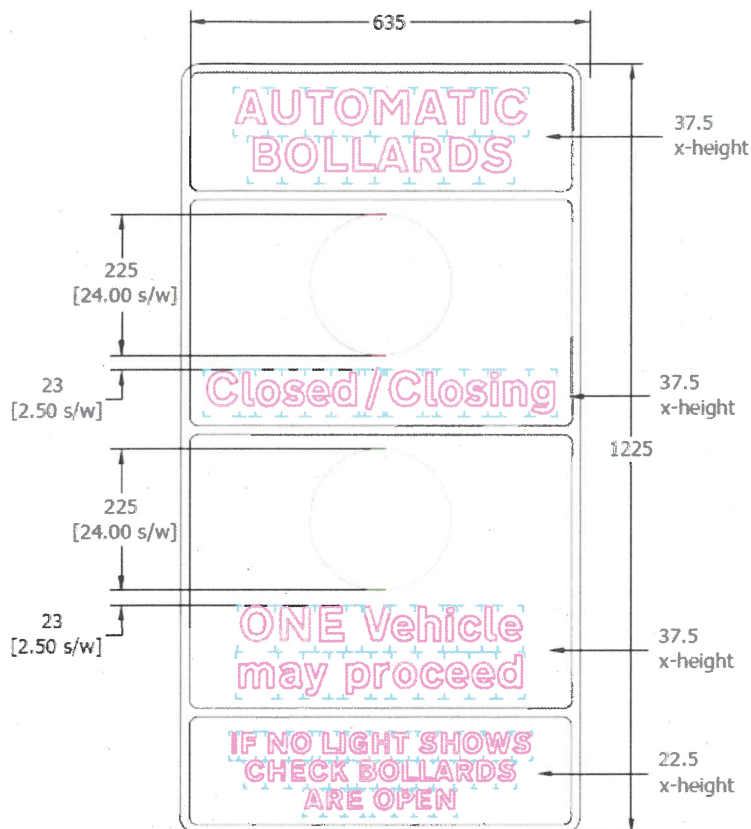

Scheme Ref.	CT Automatic Bollard Signage		
Sign Ref.	A	x-height	37.5 / 22.5
Letter colour	BLACK	SIGN FACE	
Background	WHITE	Width	635 mm
Border	BLACK	Height	1225 mm
Material	Class R3B-UK	Area	0.78 m ²

All traffic signs to be manufactured to BS EN 12899:2007
in accordance with The Traffic Signs Regulations and General Directions 2016



**Department
for Transport**

Date: 29 April 2024

Number: GT50/088/0019-1

