



Department
for Transport

Road Traffic Regulation Act 1984 Sections 64 and 65

Authorisation of traffic signs and special directions

Accessible transcript

Secretary of State for Transport's traffic authorisation of traffic signs for the purpose of informing road users of the location of the North York Moors National Park, on roads for which North Yorkshire Council is the traffic authority.

The following pages contain a copy of the text from the Secretary of State for Transport's traffic authorisation regarding the above traffic signs.

A scanned copy of the signed authorisation and supporting documents from the application are appended to this letter. The supporting material is submitted to the Department for Transport by a third party. You should refer to the party involved for accessible copies of the supporting material.



ROAD TRAFFIC REGULATION ACT 1984 – SECTIONS 64 AND 65
AUTHORISATION OF TRAFFIC SIGNS AND SPECIAL DIRECTIONS

The Secretary of State for Transport, in exercise of her powers under Sections 64 and 65 of the Road Traffic Regulation Act 1984, and of all other powers enabling her in that behalf, for the purpose of informing road users of the location of the North York Moors National Park, on roads for which North Yorkshire Council is the traffic authority, hereby:-

1. authorises the erection at appropriate sites on the said roads of a traffic sign (hereinafter referred to as “the direction sign”) consisting of a sign provided for in Schedule 12 to the Traffic Signs Regulations 2016 (Part 1 of S.I. 2016/362, “the 2016 Regulations”) save that the symbol (hereinafter referred to as “the authorised symbol”) shown in the attached drawing numbered GT50/113/0027-1 may be placed on the direction sign; and
2. directs that the provisions of Schedule 12, Parts 1 to 29 of the 2016 Regulations shall apply to the direction sign in the same manner as they apply to the signs shown in Schedule 12, Part 2 of those Regulations; and
3. directs that the provisions of Schedule 12, Parts 1 to 29 of the 2016 Regulations shall apply to the authorised symbol in the same manner as they apply to the symbol shown in Schedule 12, Part 15, Item 7 of those Regulations; and
4. directs, without prejudice to any statutory provision to the like effect, that it is a condition of this authorisation that the inclusion of the authorised symbol on the direction sign at or near the said sites shall continue to have effect only until such day as may be appointed by one month’s notice given by the Secretary of State in writing to the traffic authority for the removal or alteration of the authorised symbol and/or the direction sign, and on that day the said authorisation shall, without prejudice to the giving of any further authorisation or direction, cease to have effect.



The provisions of Regulations 5, 7, 8 and 11 of the 2016 Regulations shall apply to the direction sign in the same manner as they apply to the signs shown in Schedule 12, Part 2 of those Regulations.

The provisions of Regulations 5, 7, 8 and 11 of the 2016 Regulations shall apply to the authorised symbol in the same manner as they apply to the symbol shown in Schedule 12, Part 15, Item 7 of those Regulations.

Dated *03 February 2025*

Signed by authority of the Secretary of State

.....

A Delegated Official of the Department for Transport



Department
for Transport

**SCANNED
AUTHORISATION
AND SUPPORTING
DOCUMENTS
FOLLOW**



ROAD TRAFFIC REGULATION ACT 1984 – SECTIONS 64 AND 65
AUTHORISATION OF TRAFFIC SIGNS AND SPECIAL DIRECTIONS

The Secretary of State for Transport, in exercise of her powers under Sections 64 and 65 of the Road Traffic Regulation Act 1984, and of all other powers enabling her in that behalf, for the purpose of informing road users of the location of the North York Moors National Park, on roads for which North Yorkshire Council is the traffic authority, hereby:-

1. authorises the erection at appropriate sites on the said roads of a traffic sign (hereinafter referred to as “the direction sign”) consisting of a sign provided for in Schedule 12 to the Traffic Signs Regulations 2016 (Part 1 of S.I. 2016/362, “the 2016 Regulations”) save that the symbol (hereinafter referred to as “the authorised symbol”) shown in the attached drawing numbered GT50/113/0027-1 may be placed on the direction sign; and
2. directs that the provisions of Schedule 12, Parts 1 to 29 of the 2016 Regulations shall apply to the direction sign in the same manner as they apply to the signs shown in Schedule 12, Part 2 of those Regulations; and
3. directs that the provisions of Schedule 12, Parts 1 to 29 of the 2016 Regulations shall apply to the authorised symbol in the same manner as they apply to the symbol shown in Schedule 12, Part 15, Item 7 of those Regulations; and
4. directs, without prejudice to any statutory provision to the like effect, that it is a condition of this authorisation that the inclusion of the authorised symbol on the direction sign at or near the said sites shall continue to have effect only until such day as may be appointed by one month’s notice given by the Secretary of State in writing to the traffic authority for the removal or alteration of the authorised symbol and/or the direction sign, and on that day the said authorisation shall, without prejudice to the giving of any further authorisation or direction, cease to have effect.



Department
for Transport

GT50/113/0027



The provisions of Regulations 5, 7, 8 and 11 of the 2016 Regulations shall apply to the direction sign in the same manner as they apply to the signs shown in Schedule 12, Part 2 of those Regulations.

The provisions of Regulations 5, 7, 8 and 11 of the 2016 Regulations shall apply to the authorised symbol in the same manner as they apply to the symbol shown in Schedule 12, Part 15, Item 7 of those Regulations.

Dated *03 February 2025*

Signed by authority of the Secretary of State



CERTIFIED TRUE COPY	
	
 Department for Transport	Date: 04/02/2025

A Delegated Official of the Department for Transport

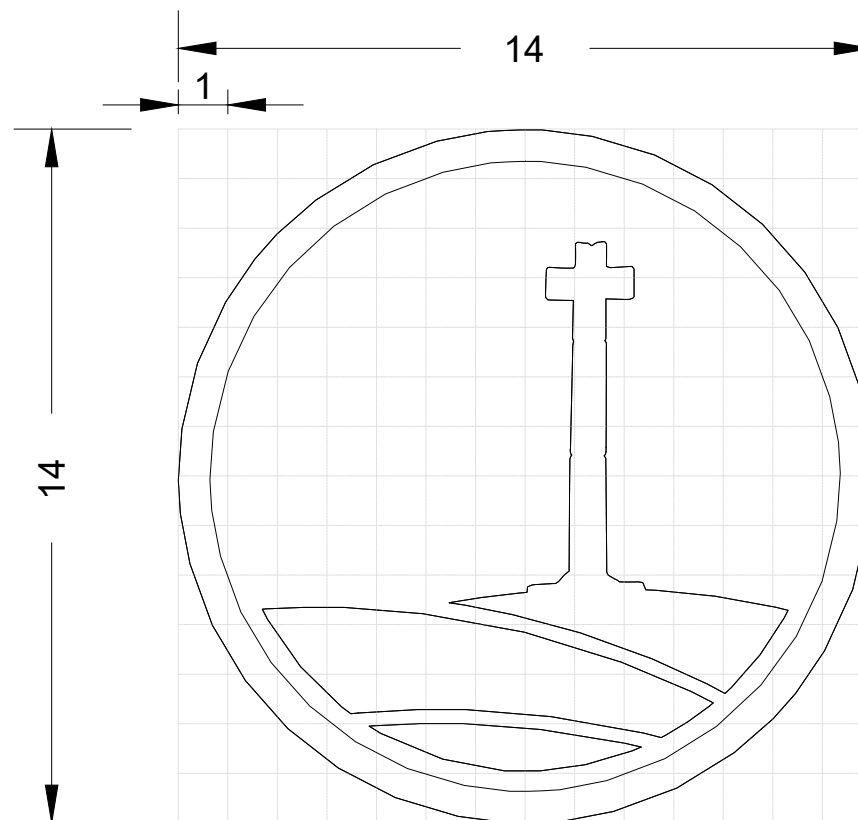

**Department
for Transport**

 Date: 31 January 2025
 Number: GT50/113/0027-1

DO NOT SCALE

NOTES:

1. THE GRID DOES NOT FORM PART OF ANY SIGN TO WHICH THE SYMBOL IS APPLIED.
2. DIMENSIONS ARE GIVEN IN GRID DIVISIONS WHICH ARE EQUAL TO 1/4 X-HEIGHT.
3. COLOURS:
 'NORTH YORK MOORS NATIONAL PARK'
 SYMBOL: WHITE
 BACKGROUND: BROWN.

P01	18/11/2024	OS	FIRST ISSUE	AR	DM
REV	DATE	BY	DESCRIPTION	CHK	APP

DRAWING STATUS: **S2 - FOR INFORMATION**

 Dale House, Mount View, Standard Way, Northallerton
 DL6 2YD, UK
 wsp.com

CLIENT:



PROJECT:

**NYMMPA STRATEGIC SIGNING
PHASE 1**

TITLE:

NYMMPA LOGO

SCALE @ A3:	CHECKED:	APPROVED:
NTS	AR	DM

PROJECT No:	DESIGNED:	DRAWN:	DATE:
70117725	OS	OS	18/11/24

DRAWING No:	REV:
70117725-WSP-HSN-PH1-CD-CH-LA	P01

© WSP UK Ltd