



Department  
for Transport

## Road Traffic Regulation Act 1984 Sections 64 and 65

### Authorisation of traffic signs and special directions

#### Accessible transcript

Secretary of State for Transport's traffic authorisation of traffic signs for the purpose of providing information to road users on roads for which Transport for London is the traffic authority.

The following pages contain a copy of the text from the Secretary of State for Transport's traffic authorisation regarding the above traffic signs.

A scanned copy of the signed authorisation and supporting documents from the application are appended to this letter. The supporting material is submitted to the Department for Transport by a third party. You should refer to the party involved for accessible copies of the supporting material.



**ROAD TRAFFIC REGULATION ACT 1984 – SECTIONS 64 AND 65  
AUTHORISATION OF TRAFFIC SIGNS AND SPECIAL DIRECTIONS**

The Secretary of State for Transport, in exercise of her powers under Sections 64 and 65 of the Road Traffic Regulation Act 1984, and all other powers enabling her in that behalf for the purpose of providing information to road users on roads for which Transport for London is the traffic authority, hereby:-

1. authorises the erection on the said roads of light signals (hereinafter referred to as “the authorised signals”) conforming to those shown in Schedule 15, Part 2, Items 11 and 12 of the Traffic Signs Regulations 2016 (Part 1 of S.I. 2016/362, “the 2016 Regulations”) save that (i) the flashing lamps may be placed in the positions shown in the attached set of drawings numbered GT50/139/0193-1 and (ii) the authorised signals may display the colour depicted in the signals shown in Schedule 15, Part 2, Items 11, 12 and 14 to the 2016 Regulations; and
2. directs, without prejudice to any statutory provision to the like effect, that it is a condition of this authorisation that the placing of the authorised signals at or near the said sites shall continue to have effect only until such day as may be appointed by one month’s notice given by the Secretary of State in writing to the traffic authority for the removal or alteration of the authorised signals and on that day the said authorisation shall, without prejudice to the giving of any further authorisation or direction, cease to have effect.

The provisions of Regulation 7 of the 2016 Regulations shall apply to the authorised signals in the same manner as they apply to those shown in Schedule 15, Part 2, Items 11, 12 and 14 to those Regulations.

The provisions of Schedule 15, Parts 1 to 5 of the 2016 Regulations shall apply to the authorised signals in the same manner as they apply to those shown in Schedule 15, Part 2, Items 11, 12 and 14 to those Regulations.

Dated *03 February 2025*

Signed by authority of the Secretary of State

.....  
A Delegated Official of the Department for Transport



Department  
for Transport

**SCANNED  
AUTHORISATION  
AND SUPPORTING  
DOCUMENTS  
FOLLOW**



**ROAD TRAFFIC REGULATION ACT 1984 – SECTIONS 64 AND 65  
AUTHORISATION OF TRAFFIC SIGNS AND SPECIAL DIRECTIONS**

The Secretary of State for Transport, in exercise of her powers under Sections 64 and 65 of the Road Traffic Regulation Act 1984, and all other powers enabling her in that behalf for the purpose of providing information to road users on roads for which Transport for London is the traffic authority, hereby:-

1. authorises the erection on the said roads of light signals (hereinafter referred to as “the authorised signals”) conforming to those shown in Schedule 15, Part 2, Items 11 and 12 of the Traffic Signs Regulations 2016 (Part 1 of S.I. 2016/362, “the 2016 Regulations”) save that (i) the flashing lamps may be placed in the positions shown in the attached set of drawings numbered GT50/139/0193-1 and (ii) the authorised signals may display the colour depicted in the signals shown in Schedule 15, Part 2, Items 11, 12 and 14 to the 2016 Regulations; and
2. directs, without prejudice to any statutory provision to the like effect, that it is a condition of this authorisation that the placing of the authorised signals at or near the said sites shall continue to have effect only until such day as may be appointed by one month’s notice given by the Secretary of State in writing to the traffic authority for the removal or alteration of the authorised signals and on that day the said authorisation shall, without prejudice to the giving of any further authorisation or direction, cease to have effect.

The provisions of Regulation 7 of the 2016 Regulations shall apply to the authorised signals in the same manner as they apply to those shown in Schedule 15, Part 2, Items 11, 12 and 14 to those Regulations.

The provisions of Schedule 15, Parts 1 to 5 of the 2016 Regulations shall apply to the authorised signals in the same manner as they apply to those shown in Schedule 15, Part 2, Items 11, 12 and 14 to those Regulations.

Dated *03 February 2025*

Signed by authority of the Secretary of State

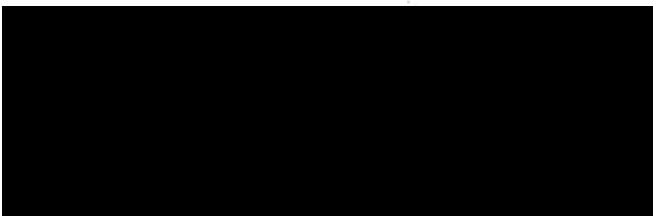

A Delegated Official of the Department for Transport

**CERTIFIED TRUE COPY**

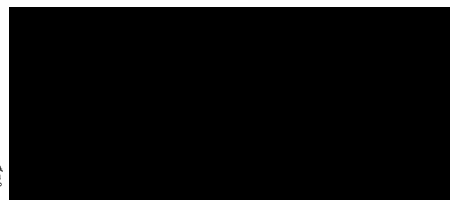

Department  
for Transport

Date:  
04/02/2025



Department for Transport

Date: 31 January 2025

Number: GT50/139/0193-1

NOTES:

Pixel Pitch:  
Wigwag 16-18 mm  
LED Full Matrix 20mm

Display Color:  
Amber & RED (Central Matrix)  
Amber (Flashing wig wags)

Resolution of Display:  
Wigwag 204 pixels  
LED Full Matrix 32(H)X32(W) pixels

Cabinet Color:  
Sand Black(RAL9005)

Max Power Consumption:  
Approx. 90 W

Avg Power Consumption:  
Approx. 30 W

Standby Power Consumption:  
Approx. 15 W

Weight:  
Approx. 23 KG

Rear Access

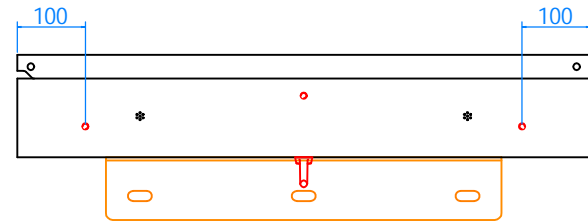

BOTTOM VIEW

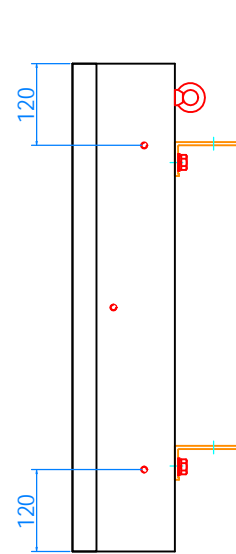

RIGHT SIDE VIEW

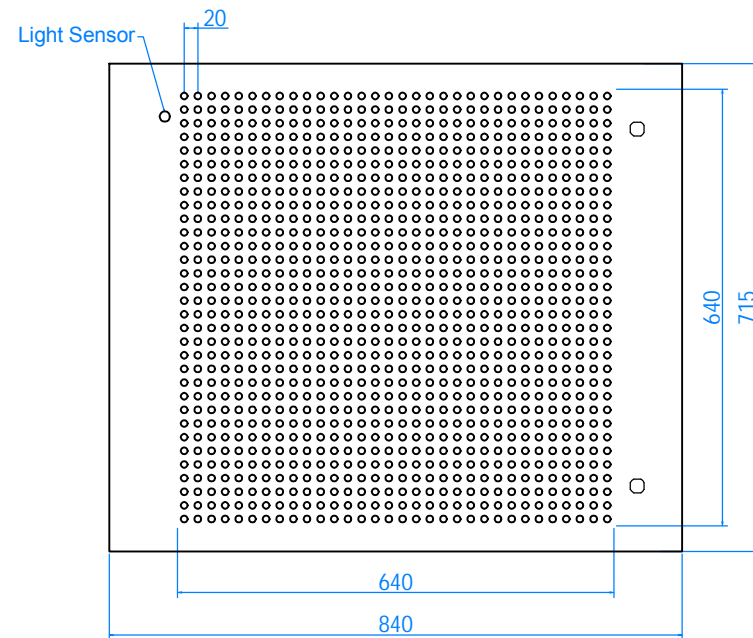

FRONT VIEW

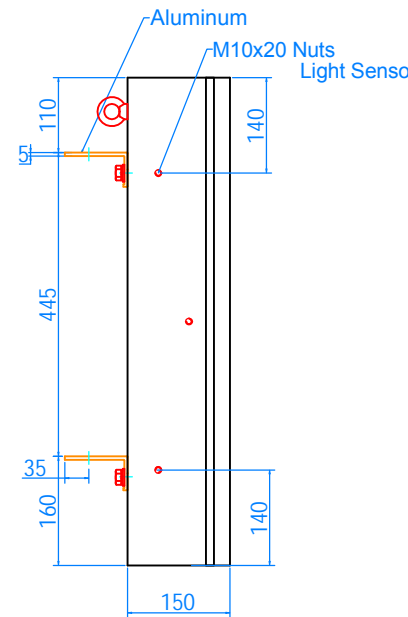

LEFT SIDE VIEW

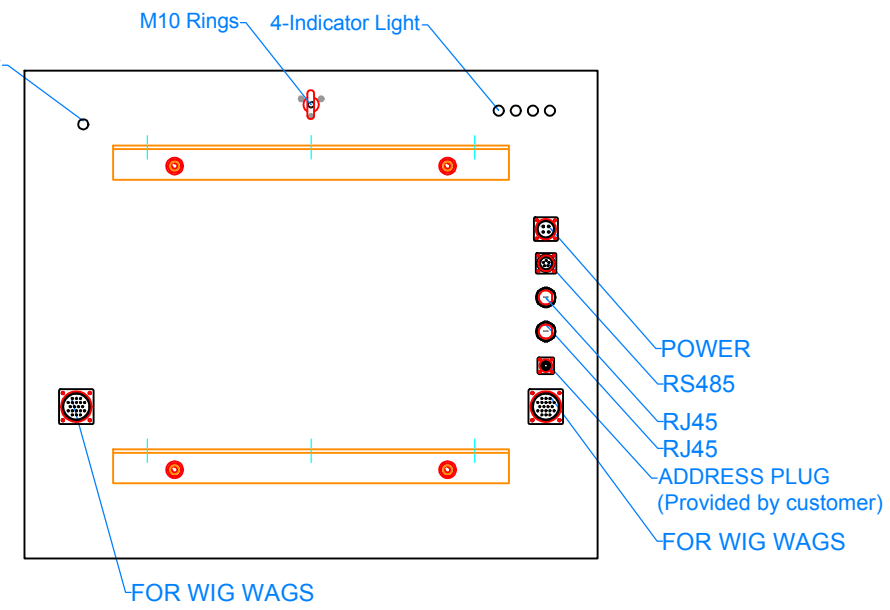

REAR VIEW

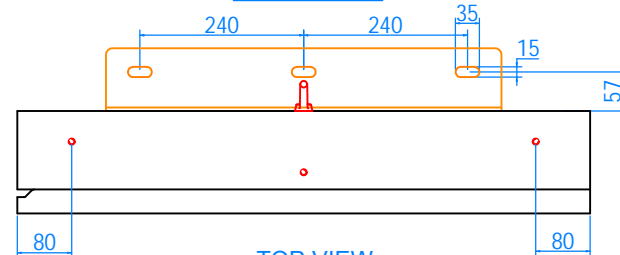

TOP VIEW



VER	DESCRIPTION	DSG	DATE
-----	-------------	-----	------

PROJECT:  
PNT20232181-2

MODEL:  
MMDMS1-211

DRAWING TITLE:

VERSION:	PAGE:	UNIT:
A15	1/2	mm
	PAGESIZE:	SCALE:
	A3	NTS

PERSON RESPONSIBLE FOR:		
DESIGNED BY:	REVIEWED BY:	AUTHORISED BY:
HJH	YJR	
DATE:	DATE:	DATE:
2024-10-08	2024-10-08	

GENERAL NOTES:  
1. All dimensions are in millimeters unless noted otherwise.  
2. This drawing should be read in conjunction with other relevant designs or drawings, if any.

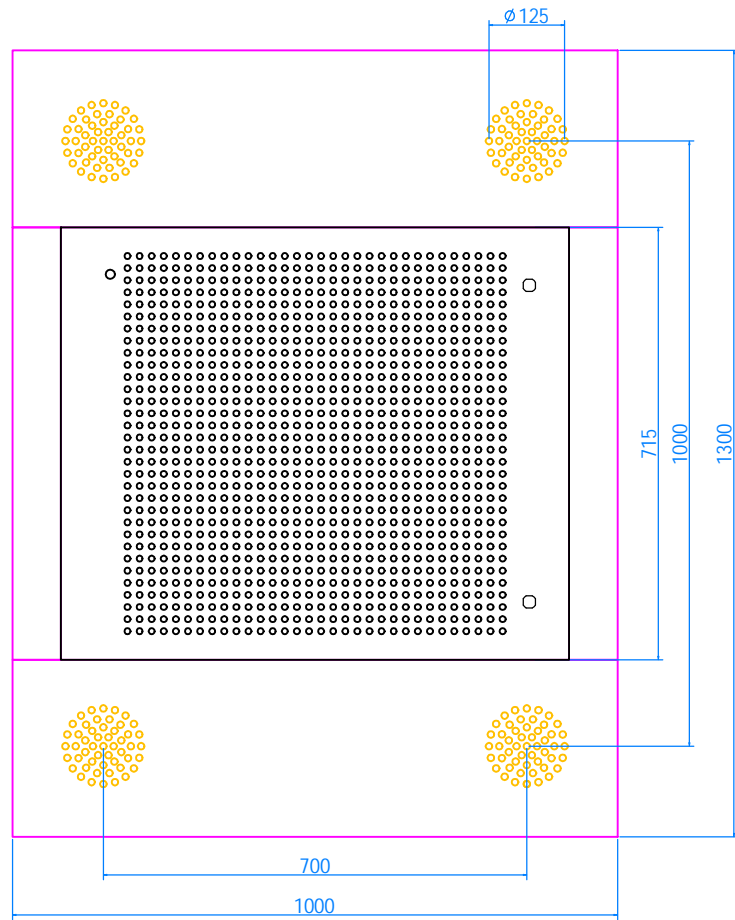

FRONT VIEW

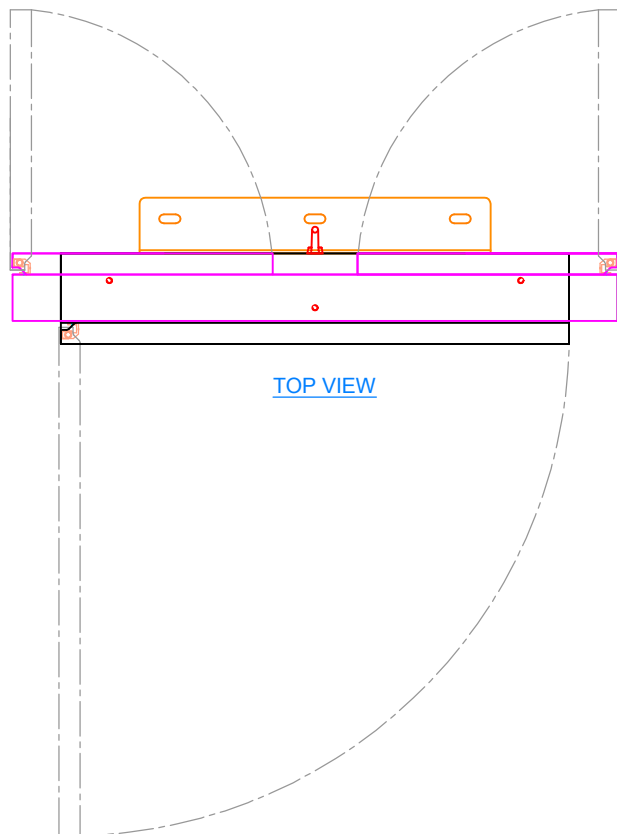

TOP VIEW

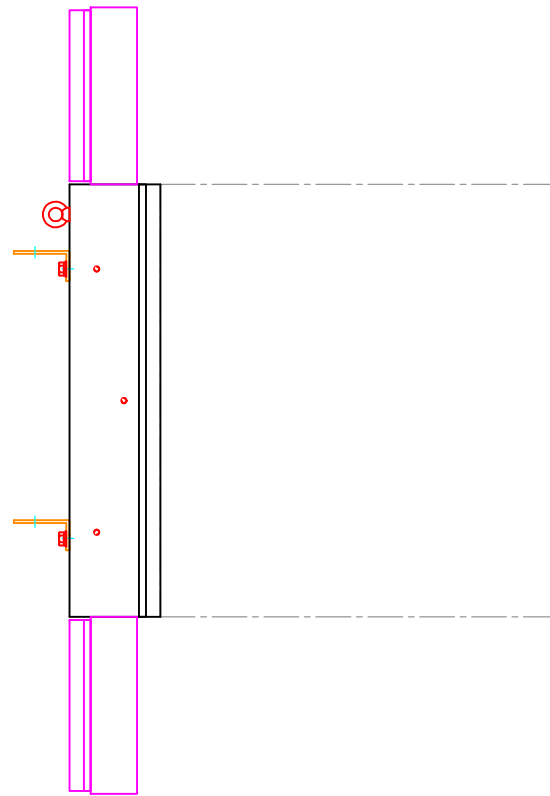

LEFT SIDE VIEW

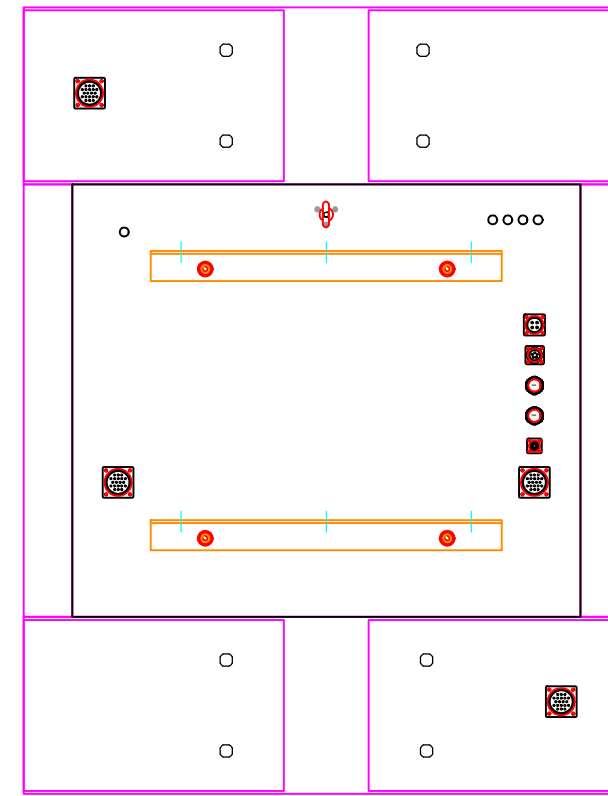

REAR VIEW

NOTES:

VER	DESCRIPTION	DSG	DATE
PROJECT:			
PNT20232181-2			
MODEL:			
DRAWING TITLE:			
VERSION:	PAGE:	UNIT:	
A15	2/2	mm	
PAGESIZE:		SCALE:	
A3		NTS	
PERSON RESPONSIBLE FOR:			
DESIGNED BY:	REVIEWED BY:	AUTHORISED BY:	
HJH	YJR		
DATE:	DATE:	DATE:	
2024-10-08	2024-10-08		

PROJECT:  
PNT20232181-2

MODEL:

DRAWING TITLE:

VER	DESCRIPTION	DSG	DATE
PROJECT:			
PNT20232181-2			
MODEL:			
DRAWING TITLE:			
VERSION:	PAGE:	UNIT:	
A15	2/2	mm	
PAGESIZE:		SCALE:	
A3		NTS	
PERSON RESPONSIBLE FOR:			
DESIGNED BY:	REVIEWED BY:	AUTHORISED BY:	
HJH	YJR		
DATE:	DATE:	DATE:	
2024-10-08	2024-10-08		

GENERAL NOTES:

1. All dimensions are in millimeters unless noted otherwise.
2. This drawing should be read in conjunction with other relevant designs or drawings, if any.

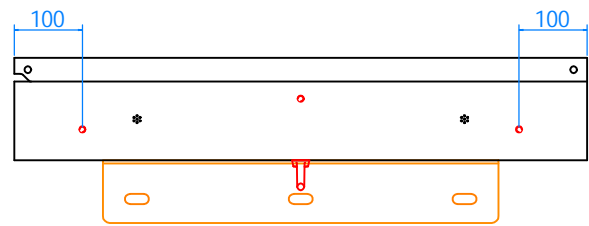

BOTTOM VIEW

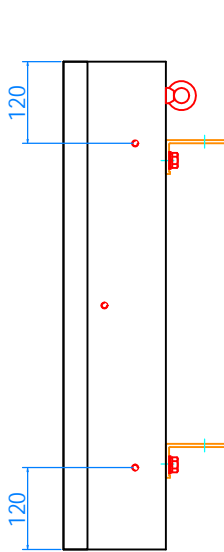

RIGHT SIDE VIEW

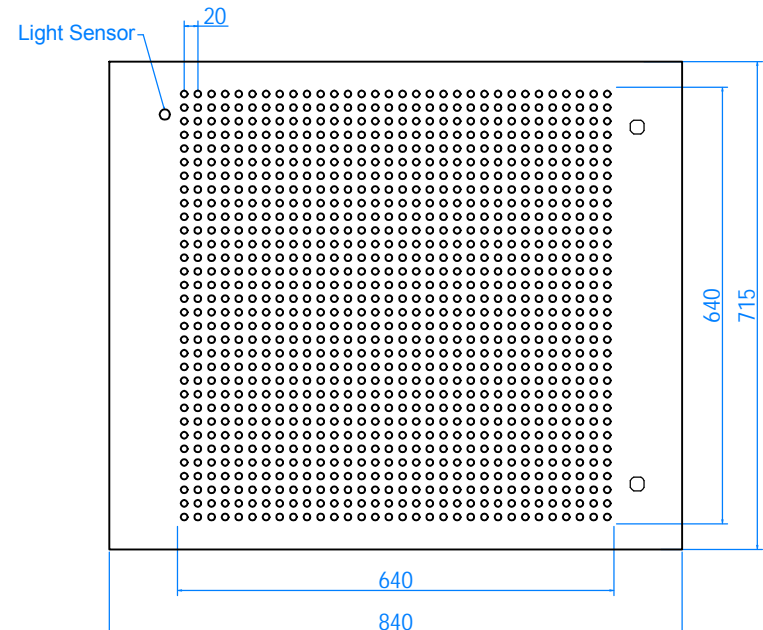

FRONT VIEW

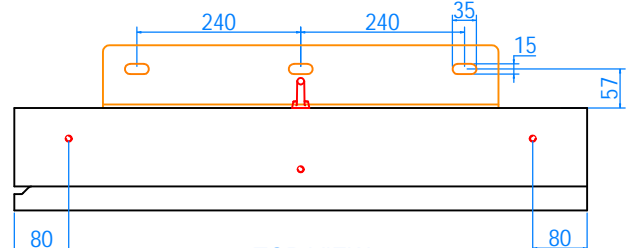

TOP VIEW

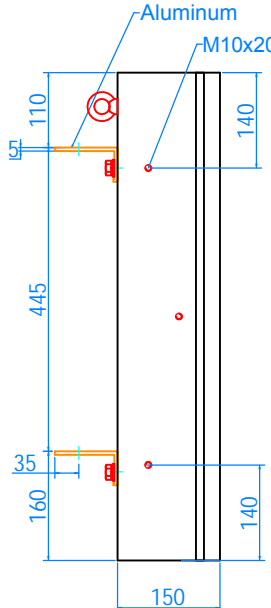

LEFT SIDE VIEW

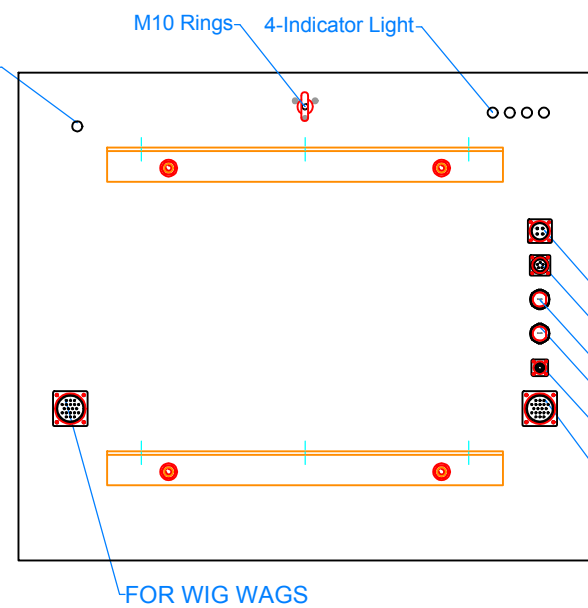

REAR VIEW



NOTES:

Pixel Pitch:  
Wigwag 16-18 mm  
LED Full Matrix 20mm

Display Color:  
Amber & RED (Central Matrix)  
Amber & RED (Flashing wig wags)

Resolution of Display:  
Wigwag 204 pixels  
LED Full Matrix 32(H)X32(W) pixels

Cabinet Color:  
Sand Black(RAL9005)

Max Power Consumption:  
Approx. 90 W

Avg Power Consumption:  
Approx. 30 W

Standby Power Consumption:  
Approx. 15 W

Weight:  
Approx. 23 KG

- POWER
- RS485
- RJ45
- RJ45
- ADDRESS PLUG (Provided by customer)
- FOR WIG WAGS

VER	DESCRIPTION	DSG	DATE
PROJECT: <b>PNT20232181-1</b>			
MODEL: <b>MMDMS1-212</b>			
DRAWING TITLE:			
VERSION: A15	PAGE: 1/2	UNIT: mm	
PAGESIZE: A3		SCALE: NTS	
PERSON RESPONSIBLE FOR:			
DESIGNED BY: HJH	REVIEWED BY: YJR	AUTHORISED BY:	
DATE: 2024-10-08	DATE: 2024-10-08	DATE:	

GENERAL NOTES:

1. All dimensions are in millimeters unless noted otherwise.  
2. This drawing should be read in conjunction with other relevant designs or drawings, if any.

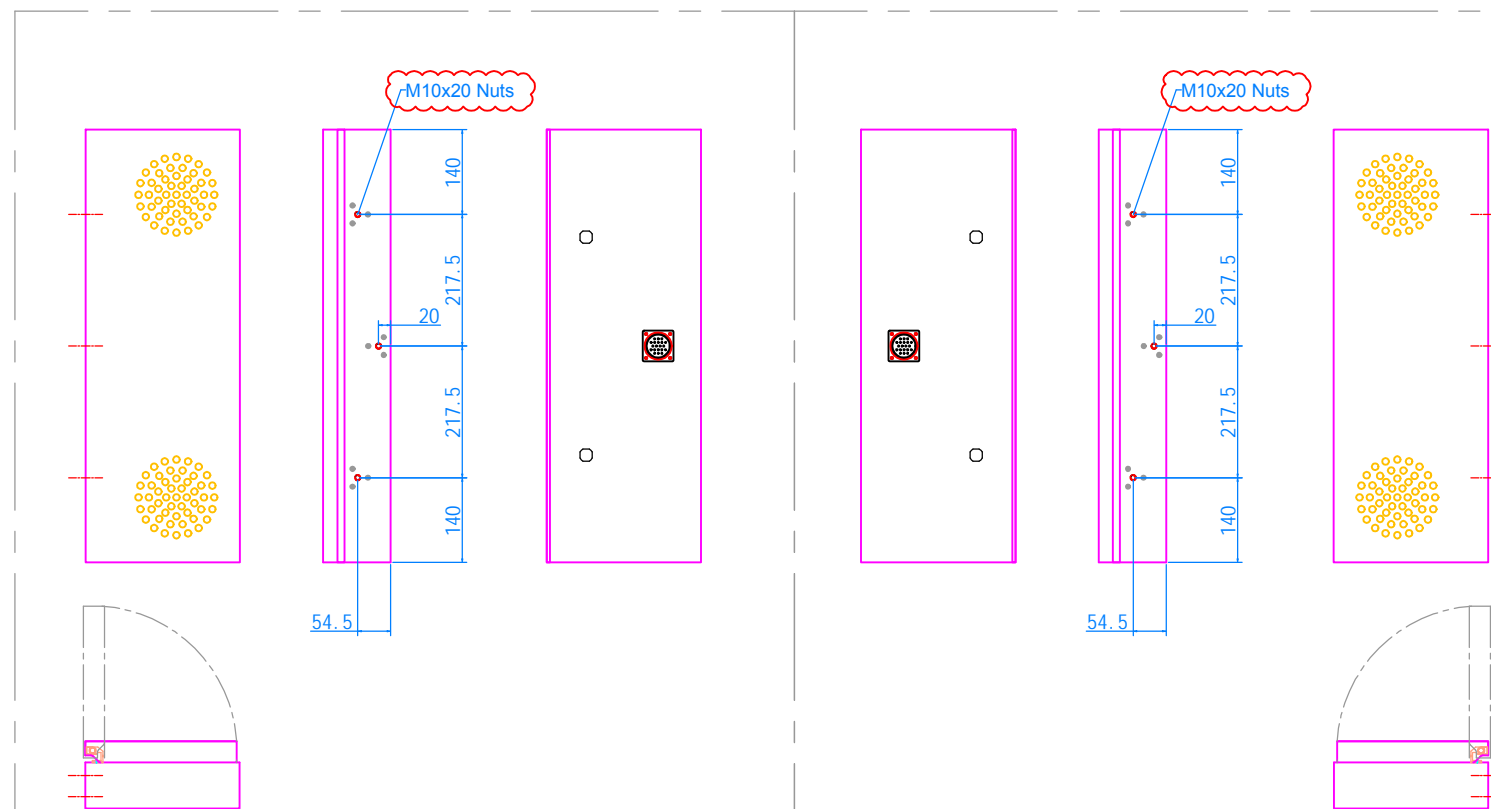
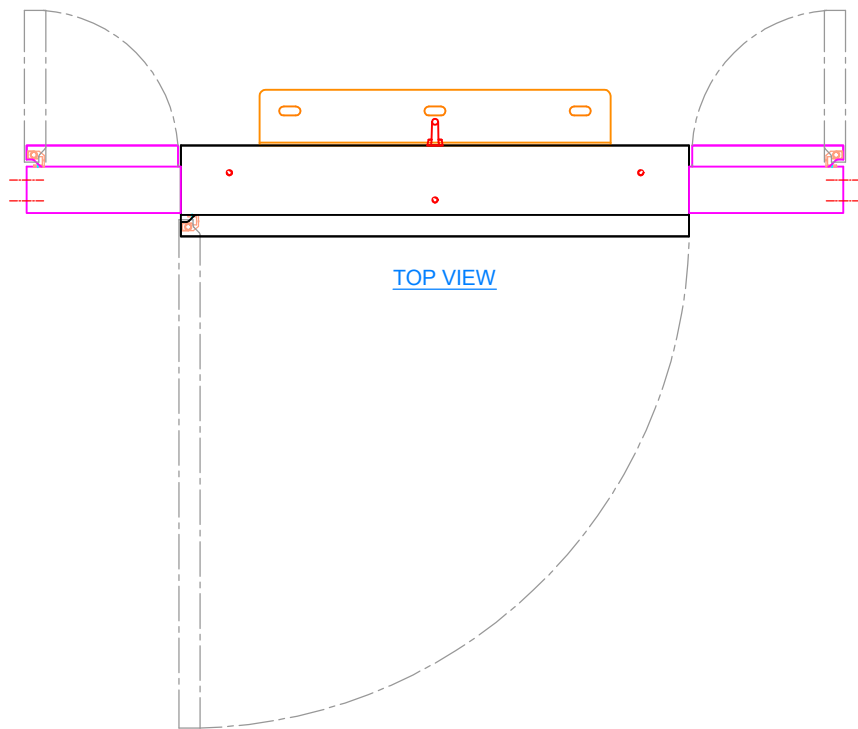
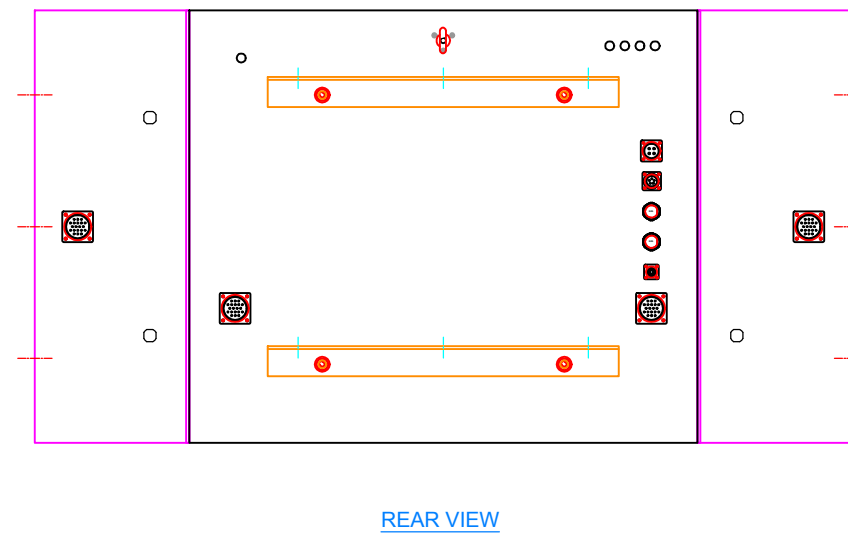
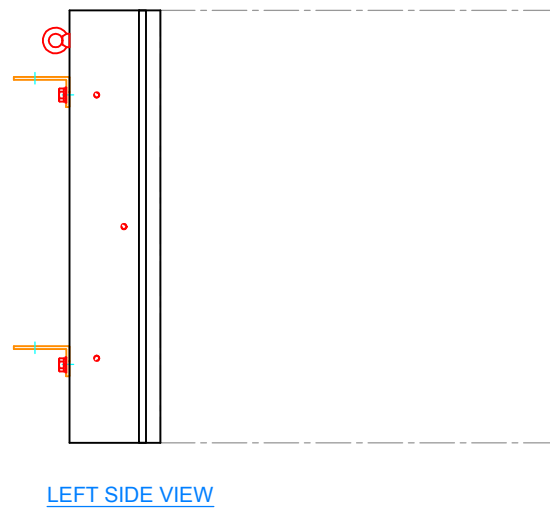
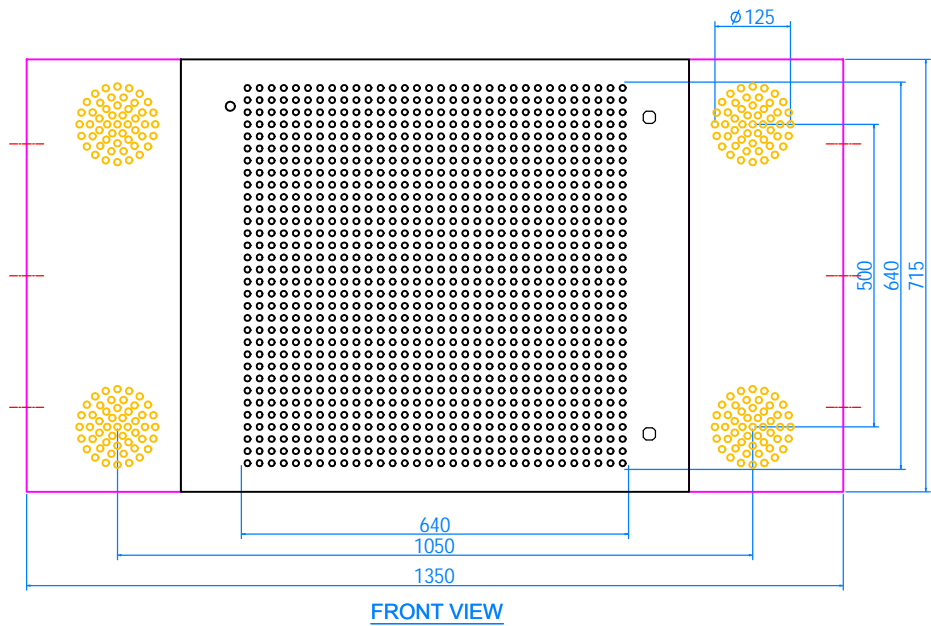

NOTES:

VER	DESCRIPTION	DSG	DATE
-----	-------------	-----	------

PROJECT:  
**PNT20232181-1**

MODEL:

DRAWING TITLE:

VERSION:	PAGE:	UNIT:
----------	-------	-------

A15	2/2	mm
-----	-----	----

PAGESIZE:	SCALE:
-----------	--------

A3	NTS
----	-----

PERSON RESPONSIBLE FOR:

DESIGNED BY:	REVIEWED BY:	AUTHORISED BY:
--------------	--------------	----------------

HJH	YJR	
-----	-----	--

DATE:	DATE:	DATE:
-------	-------	-------

2024-10-08	2024-10-08	
------------	------------	--

GENERAL NOTES:

1. All dimensions are in millimeters unless noted otherwise.
2. This drawing should be read in conjunction with other relevant designs or drawings, if any.



**NOTES:**

Pixel Pitch:  
Wigwag 16-18mm  
LED Full Matrix 20mm

Display Color:  
Amber (Central Matrix)  
Amber □:R□D:(Flashing wig wags)

Resolution of Display:  
Wigwag 204 pixels  
LED Full Matrix 32(H)X32(W) pixels

Cabinet Color:  
Sand Black(RAL9005)

Max Power Consumption:  
Approx. 90 W

Avg Power Consumption:  
Approx. 30 W

Standby Power Consumption:  
Approx. 15 W

Weight:  
Approx. 23 KG

Rear Access

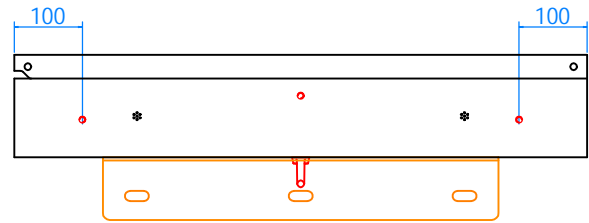

**BOTTOM VIEW**

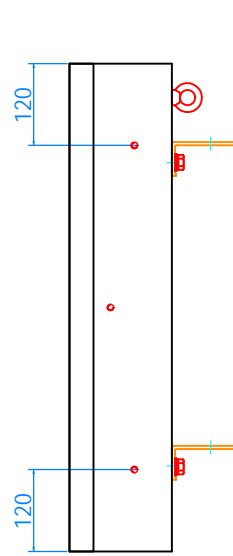

**RIGHT SIDE VIEW**

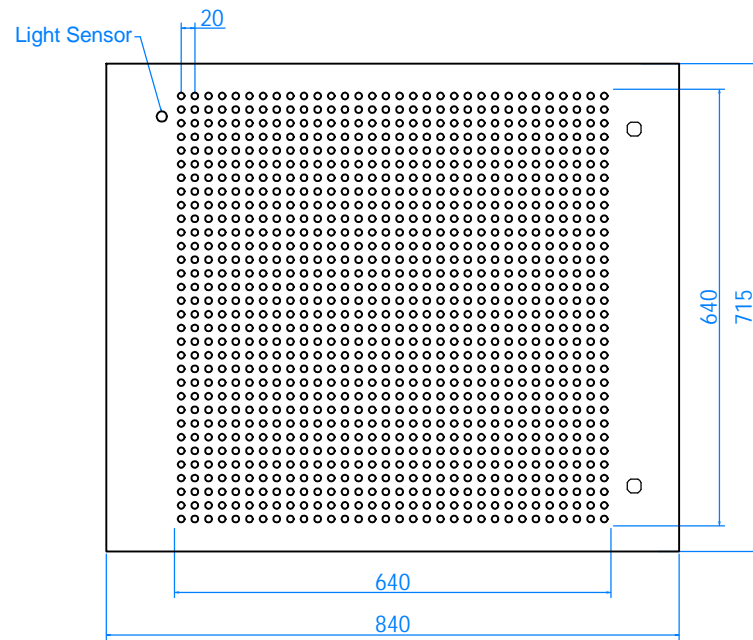

**FRONT VIEW**

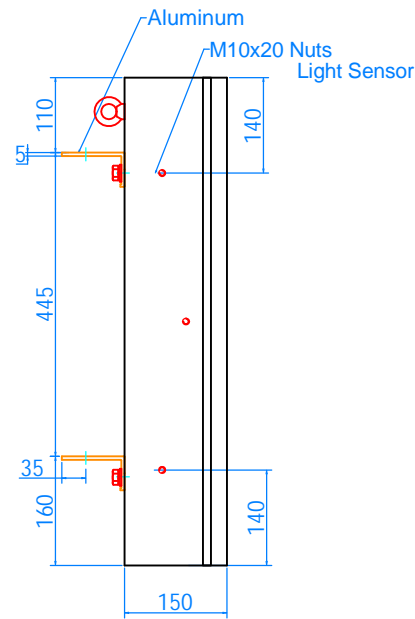

**LEFT SIDE VIEW**

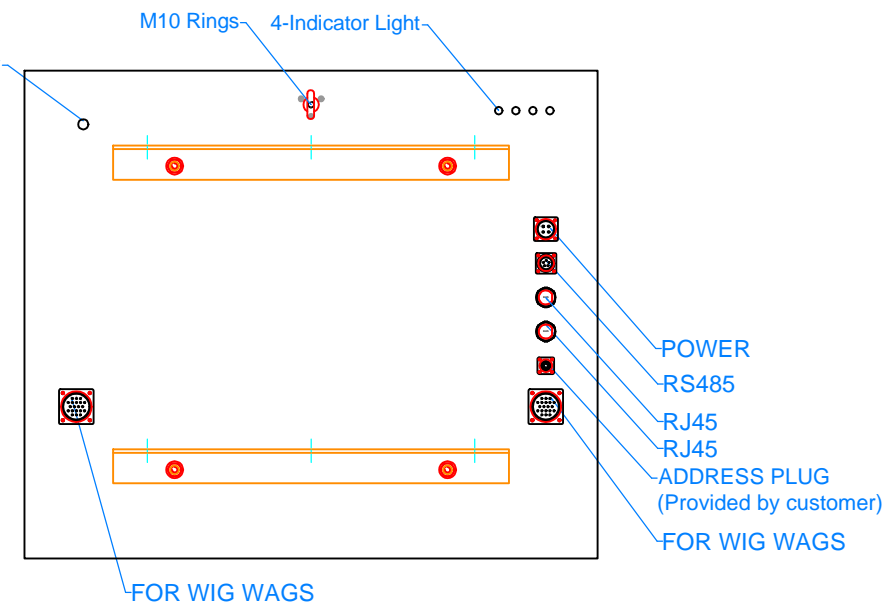

**REAR VIEW**

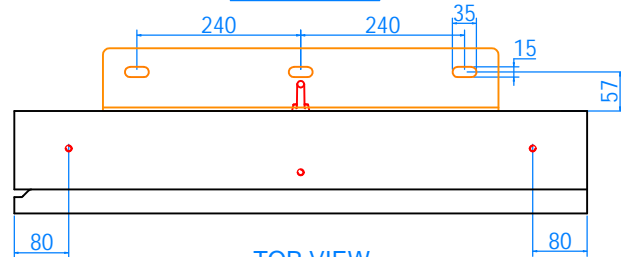

**TOP VIEW**

VER	DESCRIPTION	DSG	DATE
-----	-------------	-----	------

PROJECT:  
**PNT20242334**

MODEL:  
**MMDMS1-213**

DRAWING TITLE:

VERSION:	PAGE:	UNIT:
A1	1/2	mm
PAGESIZE: A3		SCALE: NTS
PERSON RESPONSIBLE FOR:		
DESIGNED BY: CJS	REVIEWED BY: YJR	AUTHORISED BY:
DATE: 20241107	DATE: 20241107	DATE:

**GENERAL NOTES:**

1. All dimensions are in millimeters unless noted otherwise.  
2. This drawing should be read in conjunction with other relevant designs or drawings, if any.



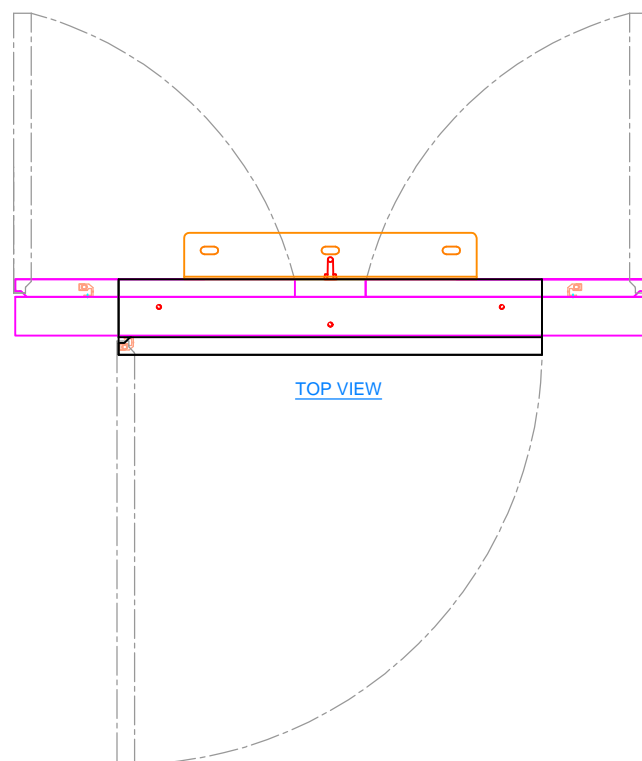
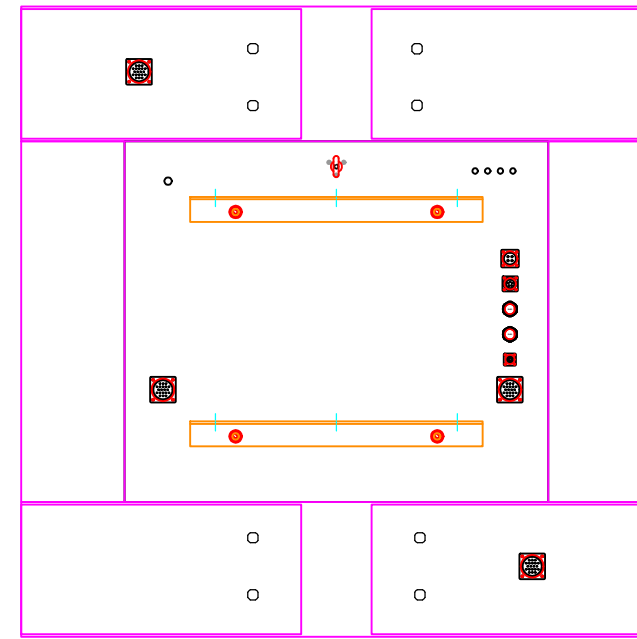
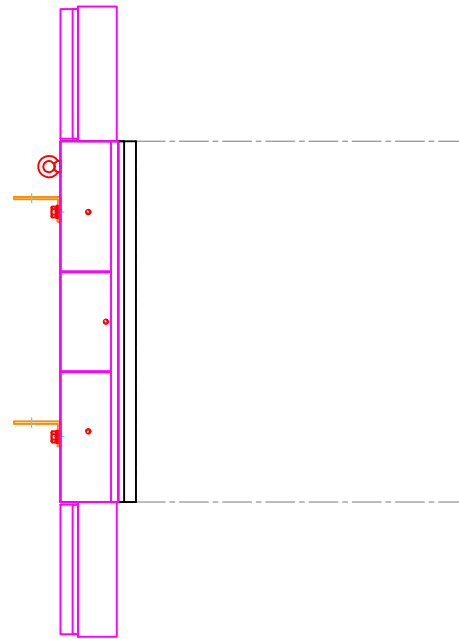
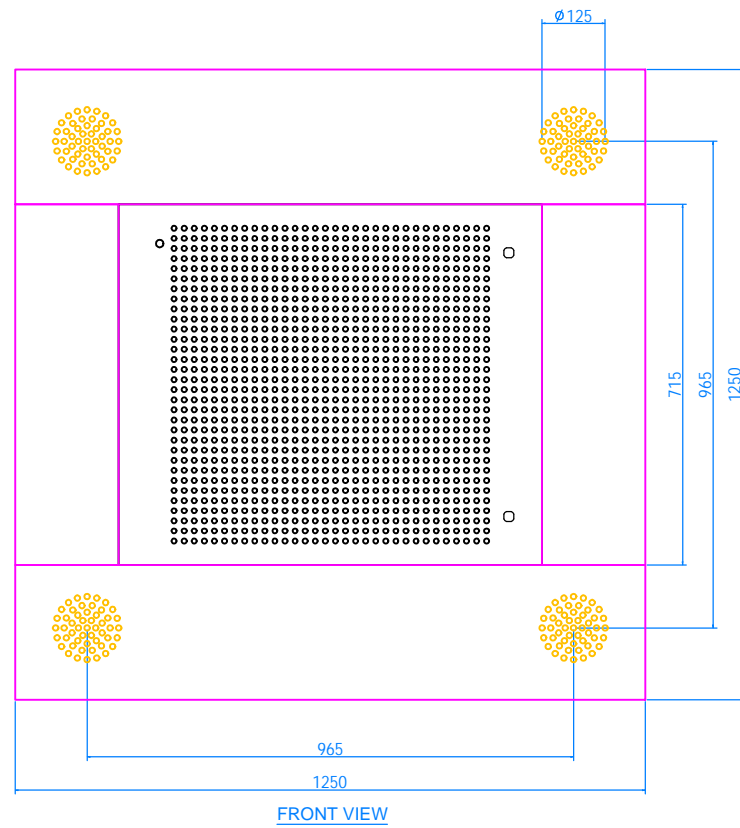
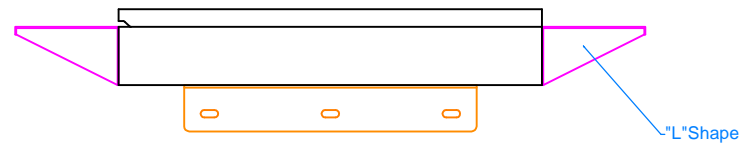

NOTES:

VER	DESCRIPTION	DSG	DATE
-----	-------------	-----	------

PROJECT:  
PNT20242334

MODEL:  
MMDMS1-213

DRAWING TITLE:

VERSION:	PAGE:	UNIT:
A1	2/2	mm
	PAGESIZE:	SCALE:
	A3	NTS

PERSON RESPONSIBLE FOR:		
DESIGNED BY:	REVIEWED BY:	AUTHORISED BY:
CJS	YJR	
DATE:	DATE:	DATE:
20241107	20241107	

GENERAL NOTES:  
 1. All dimensions are in millimeters unless noted otherwise.  
 2. This drawing should be read in conjunction with other relevant designs or drawings, if any.